

Process to Instrument Valves

Monoflanges and VariAS-Blocks

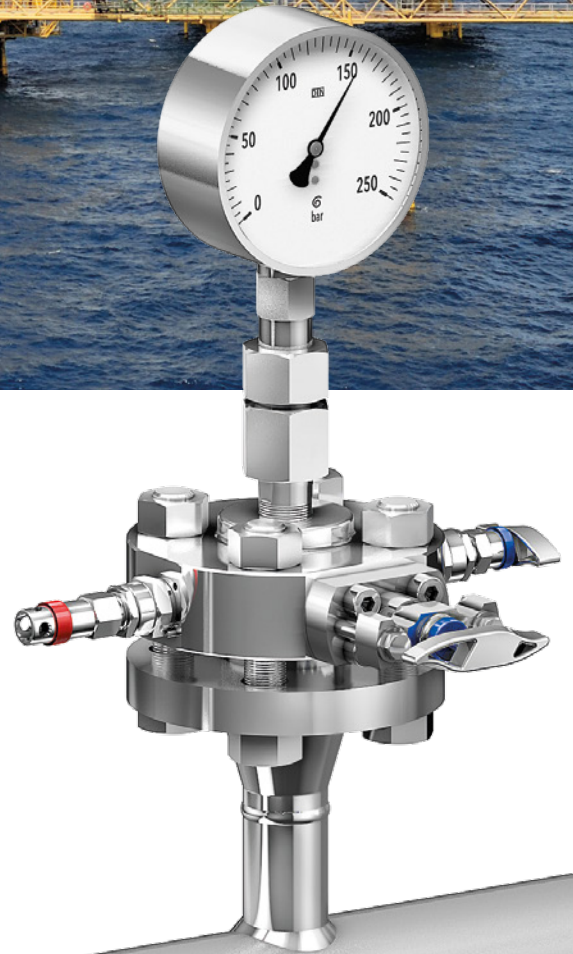
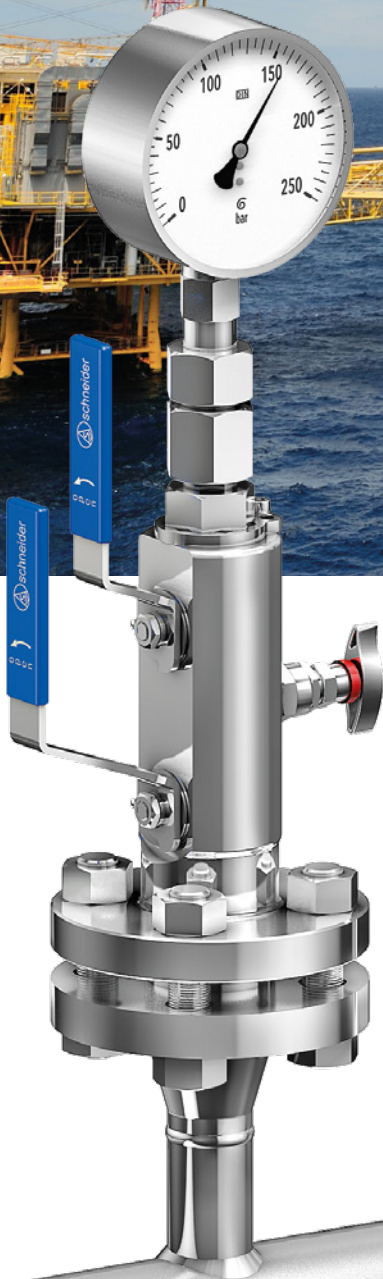

Optionally Available

Introduction

The AS-Schneider Group with its headquarters in Germany is one of the World's Leading Manufacturers of Instrumentation Valves and Manifolds. AS-Schneider offers a large variety of Process to Instrument Valves such as Monoflanges, VariAS-Blocks and Accessories needed for the instrumentation installations globally.

The AS-Schneider Process to Instrument Valves are designed to overcome the problems of traditional assemblies on primary isolation duties. By combining piping and instrument valves in a single assembly, they provide weight and space savings, along with other benefits including reduced potential leak points and safer hook-up. This more compact and efficient arrangement reduces not only pipework vibration and associated stress but also installation and maintenance costs.

Selection can be made from a comprehensive range of bodies with a variety of connections and material options, optimising installation and access opportunities. Many of the valves shown in this catalogue are available from stock or within a short period of time. The dimensions shown in this catalogue apply to standard types. If you need the dimensions for your individual type please contact the factory.

Continuous product development may from time to time necessitate changes in the details contained in this catalogue. AS-Schneider reserves the right to make such changes at their discretion and without prior notice.

All dimensions shown in this catalogue are approximate and subject to change.



Conventional Solution

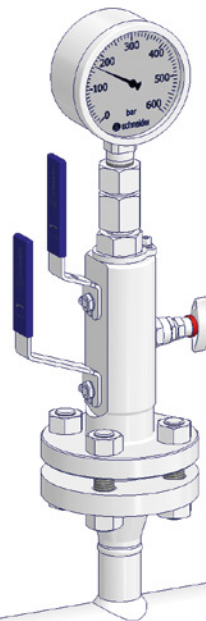

VariAS-Block

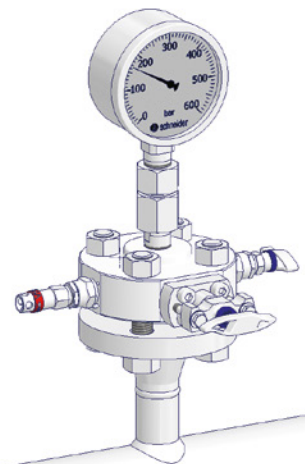

Monoflange

	Introduction	page 2
	Contents	page 3
Monoflanges	Product Description & General Features	page 4-5
	Valve Head Units	page 6-9
	Options	page 10-11
	Assemblies	page 12
	Weights and Dimensions	page 13-14
	Ordering Information	page 15
VariAS-Blocks	Product Description & General Features	page 16-17
	Standard Valve Designs and Options – Bore Size 10 mm (0.39")	page 18-19
	Standard Valve Designs and Options – Bore Size 14 mm (0.55") and 20 mm (0.79") and Standard Needle Valve	page 20-21
	Fugitive Emission Application Designs	page 22-23
	Options	page 24
	Injection and Sampling Applications	page 25
	Weights and Dimensions	page 26-27
	Pressure Ratings, Codes and Specifications	page 28
	API 6A — 10k/15k VariAS-Blocks	page 29
	DVT (TAT) — VariAS-Blocks MESC SPE 77/300	page 30-31
	Ordering Information	page 32
	Accessories for Monoflanges and VariAS-Blocks	page 33
	DB&B Piping Ball Valves – Taurus Series	page 34
	Technical Service Portal - Digital Valve Plate	page 35

Monoflanges

Monoflanges

AS-Schneider Monoflanges are designed to replace conventional multiple-valve installations currently in use for interface with pressure measuring systems. By combining customer specified valves into a single manifold, the number of leak paths is considerably reduced and the mass of the system is lowered reducing the stresses from loading and vibration. The AS-Schneider Monoflange Series are available as Process Monoflanges and Instrument Monoflanges.

Process Monoflanges

Process Monoflanges are designed to replace the traditional primary isolation valve and are close coupled to the process piping flange, for connecting process to instruments. The primary isolation valve needs to be of process design, therefore it's a valve with OS&Y Bolted Bonnet. The secondary isolation valve and the bleed valve are provided with screwed bonnets. The combining of piping and instrument valves into a single unit has benefitted various markets.

Instrument Monoflanges

Instrument Monoflanges are close coupled to a pre-installed primary isolation valve to provide a compact Instrument Double Block & Bleed Valve or are used when primary isolation valves with an OS&Y Bolted Bonnet are not required. The needle valves of the Instrument Monoflanges are provided with a screwed bonnet.

Block

1st Isolate: OS&Y

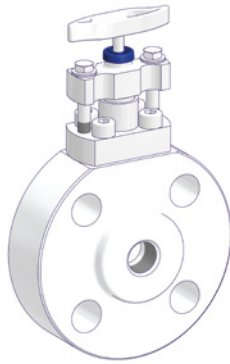

Block

1st Isolate: Needle

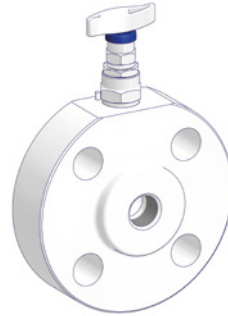

Block & Bleed

1st Isolate: OS&Y
Vent: Needle

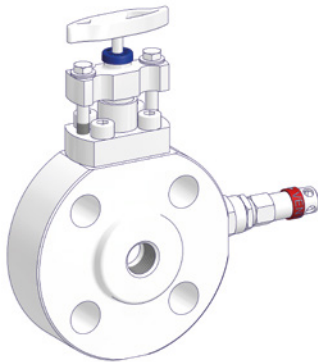

Block & Bleed

1st Isolate: Needle
Vent: Needle

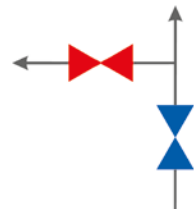

Double Block & Bleed

1st Isolate: OS&Y
2nd Isolate: Needle
Vent: Needle

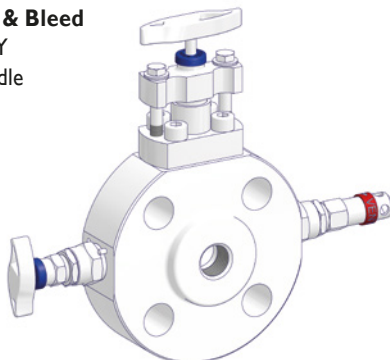

Double Block & Bleed

1st Isolate: Needle
2nd Isolate: Needle
Vent: Needle

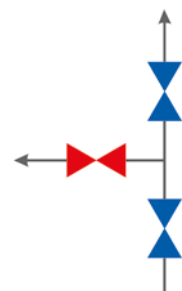
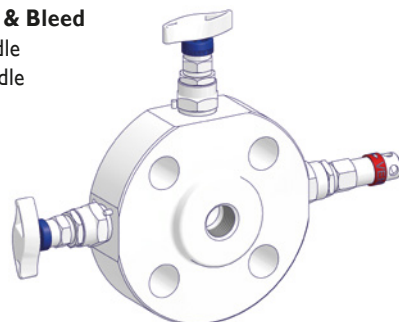

Body Material Options

Material Group	AS Material Designation	Material No.	Short Name	Equivalent UNS-No.	Material Grade acc. to ASTM	Monoflanges
Carbon Steel	A105				A105	Optional
	LF2				LF2	Optional
Austenitic Stainless Steel	316 quadruple certified*	1.4401	X5CrNiMo17-12-2	S31600	316	Standard
		1.4404	X2CrNiMo17-12-2	S31603	316L	Standard
	6Mo	1.4547	X 1CrNiMoCuN20-18-7	S31254		Standard
Austenitic-Ferritic Stainless Steel	Duplex	1.4462	X2CrNiMoN22-5-3	S31803	F51	Standard
	Superduplex	1.4410	X2CrNiMoN25.7.4	S32750	F53	Standard
		1.4501	X2CrNiMoCuWN25.7.4	S32760	F55	Optional
Nickel Based Alloys	Alloy 400	2.4360	NiCu30Fe	N04400		Standard
	Alloy C-276	2.4819	NiMo 16 Cr 15 W	N10276		Standard
	Alloy 625	2.4856	NiCr22Mo9Nb	N06625		Standard
	Alloy 825	2.4858	NiCr21Mo	N08825		Optional

* Quadruple certified means 316 / 316L / 1.4401 / 1.4404

Standard Features

- Bore Size 5 mm (0.197")
- ASME B16.5 Flange Connections
 - Flange Size 1/2" to 3" (DN15 to DN80)
 - Flange Class 150 to 2,500
- Outlet Connection 1/2 NPT Female
- Vent Connection 1/4 NPT Female
- Vent Valve with Anti-Tamper Head Unit incl. AT-Key. Anti-Tamper Head Unit Options see Page 9.
- Monoflanges with OS&Y Bolted Bonnet and Graphite Packing are Fire Safe Tested and Certified according to ISO 10497. See also Page 7.

Needle Seal:

PTFE and Graphite Packings are available for all valve types.

Sour Gas Service:

Wetted parts according to a.m. material list are supplied as standard according to NACE MR0175/MR0103 and ISO 15156 / ISO 17945 (latest issue).

Pressure Test:

A shell test and a seat leakage test are performed at 1.5 times the max. allowable (Working) Pressure (PS) acc. to EN 12266-1 – P10, P11 and P12 respectively MSS-SP61 (and complies also with ASME B31.1 and B31.3) at every standard AS-Schneider Monoflange → 100% Pressure Tested!

Certification:

Certified Mill Test Report (CMTR) as inspection certificate 3.1 acc. to EN 10 204 for valve body material and pressure test available on request.

The manifolds can be provided by default with a

- CRN Certificate
- EAC Certificate – Manifolds are marked with EAC

Optional Features

- Bore Size 10 mm (0.39") – See Page 10
- API Flange Connections (up to 689 bar [10,000 psi])
- EN 1092-1 Flange Connections
- Needle Seal with FKM O-Ring and Bellows Sealed Head Units
- Choices of Needle Tip Materials such as Stellite and Soft Tips
- Swivel Gauge Connections – Integral Type and as Accessory, see also Page 26
- Pressure Tested according to API 598
- Hydrogen Service

Fugitive Emission Application:

For Fugitive Emission Applications AS-Schneider is providing TA-Luft 2021 and ISO 15848 solutions.

For more details see Page 8.

Oxygen Service:

AS-Schneider offers an option with Reinforced PTFE Packing cleaned and lubricated for Oxygen Service:

Pressure-Temperature Rating:

Max. 420 bar (6,092 psi) @ 60°C (140°F)

Max. 200°C (392°F) @ 90 bar (1,305 psi)

Not every Valve Type is available for Oxygen and Hydrogen Service!

If you don't find your options in this catalogue, please contact the factory.

Standard Valve Head Units

Standard Needle Valves

Screwed Bonnet – Needle Seal: Packing

Features

- Integral Valve Seat – Metal to metal seated
- Non-rotating Needle
- External Stem Thread – Packing below stem threads. Stem threads are protected from process media (non-wetted).
- Stem with Cold Rolled Threads
- Blow-out Proof Needle
- Back Seat – Metal to metal secondary needle seal
- Lock Pin – Eliminates unauthorized removal of the bonnet
- Color Coded Dust Cap for operating thread protection
- Needle Seal: Standard Packing in PTFE and Graphite
- Max. allowable (Working) Pressure (PS) acc. to ASME B16.34 Class 2500 – 689 bar (10,000 psi) optional
- Anti-Tamper Valve Head Options available
- All Non-wetted Parts in 316 Stainless Steel

Standard Isolate Valve

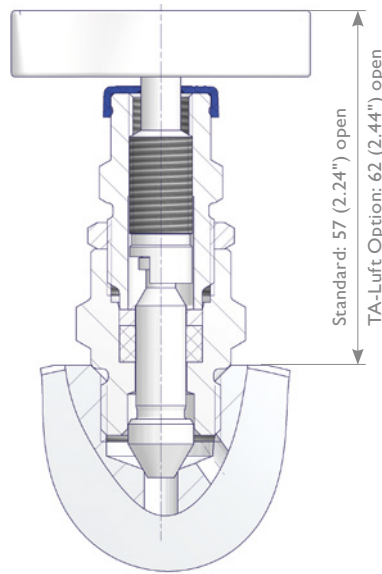

Standard Vent Valve

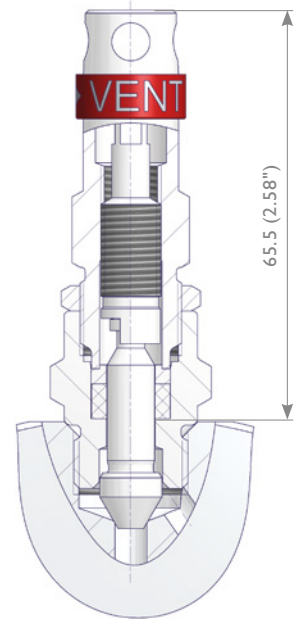

Color Coded Dust Cap

For stem thread protection:

- Isolate BLUE
- Vent/Test RED
- Equalize GREEN

Color Coded Options

Following options are also color coded below dust cap:

- Oxygen Service WHITE
- Graphite Packing BLACK
- TA-Luft Option MAGENTA
- Hydrogen LIGHT BLUE

For example

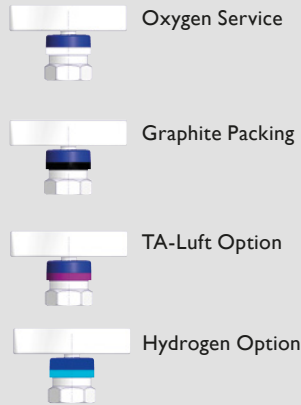

Components	Carbon Steel	Stainless Steel	Exotic Alloys						
	Material / Material No.								
Body	A 105 resp. LF2								
Bonnet		316 / 316L	Alloy 400	Alloy C-276	Duplex	Superduplex UNS S32750	Alloy 625	6Mo	
Needle	316 / 316L								
Pipe Plug									
Valve Stem			316 / 316L						
Gland			316						
Packing			PTFE or Graphite						
Stem Nut/Yoke			316						
Lock Nut			316						
Set Screw			316						
T Handle			316						
Lock Pin			A4 (316)						

Wetted components listed in **bold**.

Needle Valves with OS&Y Bolted Bonnet

OS&Y Bolted Bonnet – Standard Packing

Features

- Integral Valve Seat – Metal to metal seated
- Non-rotating Needle
- External Stem Thread – Packing below stem threads.
Stem threads are protected from process media (non-wetted).
- Stem with Cold Rolled Threads
- Blow-out Proof Needle
- Spring Washers for compensation of thermal expansion
- Back Seat – Metal to metal secondary needle seal
- Color Coded Dust Cap for operating thread protection
- Needle Seal:
 - Standard Packing in PTFE and Graphite
- Bonnet Seal Ring: Graphite
- Fire Safe approved acc. to ISO 10497 and API 607 – Graphite Packing only
- Max. allowable (Working) Pressure (PS) acc. to ASME B16.34 Class 2500 – 689 bar (10,000 psi) optional
- Anti-Tamper Valve Head Options available
- All Non-wetted Parts in 316 Stainless Steel

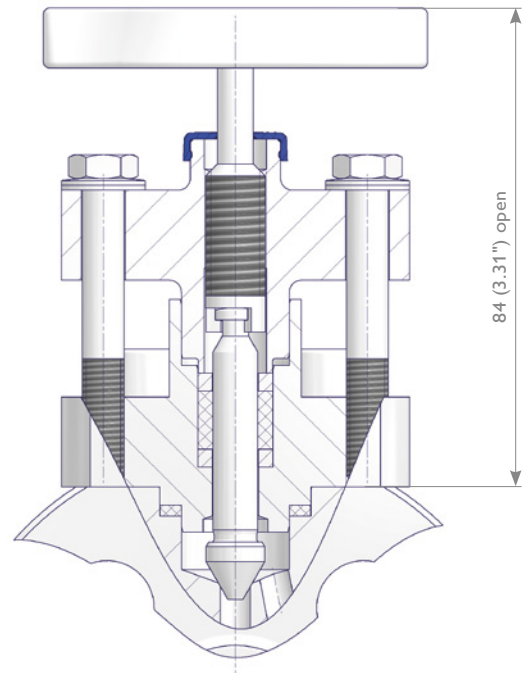

Pressure-Temperature Rating

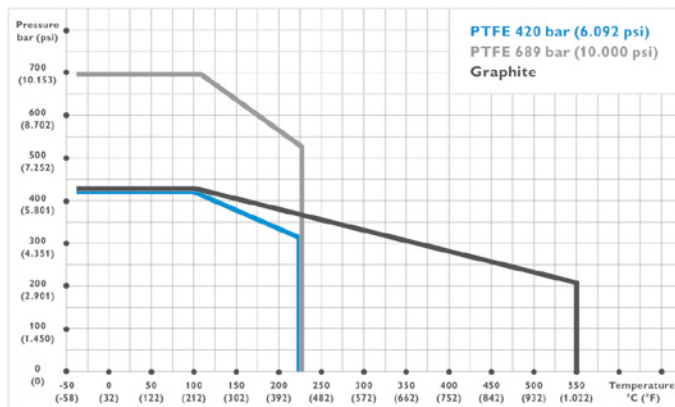

Above-mentioned Pressure-Temperature Rating is based on the standard material 316 stainless steel.

Other materials as shown on page 5 and 6 might have different Pressure-Temperature Ratings.

Manufactured according to the following Codes and Specifications

- ASME B31.3 Process Piping Specification for Pipeline Valves
- ASME B16.34 Valves – Flanged, Threaded and Welding End
- ASME B16.5 Pipe Flanges and Flanged Fittings
- NACE MR0175/ ISO 15156 / ISO 17945 (latest issue) Petroleum and Natural Gas Industries – Materials for use in H₂S-containing Environments in Oil and Gas Production
- API 598 Valve Inspection and Testing
- ISO 5208 Industrial Valves – Pressure Testing of Metallic Valves
- ISO 10497 Fire Test for Soft-Seated Quarter Turn Valves Testing of Valves. Fire Type-testing Requirements
- MSS SP-25 Standard Marking System for Valves, Fittings, Flanges, and Unions
- MSS SP-61 Pressure Testing of Valves

Valve Head Units for Fugitive Emission Applications

Needle Valves acc. to ISO 15848

Screwed Bonnet – Type 1 O-Ring Needle Seal + Graphite Packing
 Type 3 PTFE Packing
 Type 4 Graphite Packing

Features

- Integral Valve Seat – Metal to metal seated
- Non-rotating Needle
- External Stem Thread – Packing below stem threads. Stem threads are protected from process media (non-wetted).
- Stem with Cold Rolled Threads
- Blow-out Proof Needle
- Back Seat – Metal to metal secondary needle seal
- Lock Pin – Eliminates unauthorized removal of the bonnet
- Color Coded Dust Cap for operating thread protection
- Needle Seal:
 Standard Packing in PTFE, Graphite, or Graphite plus FKM O-Ring - RGD resistant (RGD = Rapid Gas Decompression)
- Max. allowable (Working) Pressure (PS):
 420 bar (6,092 psi)
- Anti-Tamper Valve Head Options available
- All Non-wetted Parts in 316 Stainless Steel
- Types also comply with the requirements of TA-Luft 2021

ISO FE Performance Data

ISO FE Type 1:
 Class A 1,500 cycles / -29°C to 40°C
 (-20°F to 104°F)
 Class A 500 cycles / -29°C to 200°C
 (-20°F to 392°F)
 Class B 1,500 cycles / -29°C to 200°C
 (-20°F to 392°F)

ISO FE Type 3:
 Class B 1,500 cycles / -29°C to 200°C
 (-20°F to 392°F)

ISO FE Type 4:
 Class A 205 cycles / -50°C to 400°C
 (-58°F to 752°F)

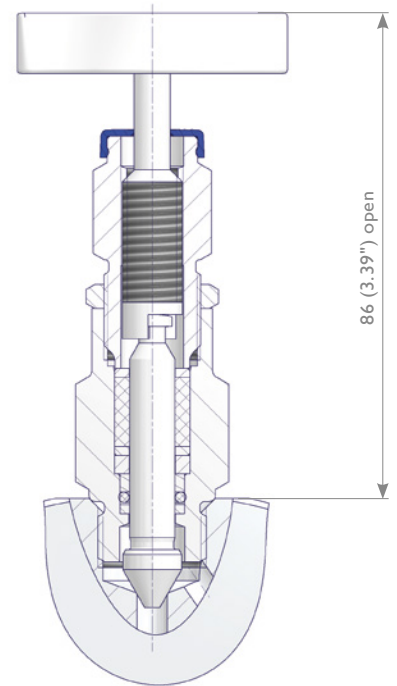

Picture shows ISO FE Type 1

OS&Y Needle Valves acc. to ISO 15848

OS&Y Bolted Bonnet – Type 1 O-Ring Needle Seal + Graphite Packing
 Type 3 PTFE Packing
 Type 4 Graphite Packing

Features

- Integral Valve Seat – Metal to metal seated
- Non-rotating Needle
- External Stem Thread – Packing below stem threads. Stem threads are protected from process media (non-wetted).
- Stem with Cold Rolled Threads
- Blow-out Proof Needle
- Spring Washers for compensation of thermal expansion
- Back Seat – Metal to metal secondary stem seal
- Colour Coded Dust Cap for operating thread protection
- Needle Seal:
 Standard Packing in PTFE, Graphite, or Graphite plus FKM O-Ring - RGD resistant
- Bonnet Seal Ring: Graphite
- Fire Safe approved acc. to ISO 10497 and API 607 – Graphite Packing only
- Max. allowable (Working) Pressure (PS):
 420 bar (6,092 psi)
- Anti-Tamper Valve Head Options available
- All Non-wetted Parts in 316 Stainless Steel
- Types also comply with the requirements of TA-Luft 2021

ISO FE Performance Data

Class A 2,500 cycles / -29°C to 40°C
 (-20°F to 104°F)
 Class A 500 cycles / -29°C to 200°C
 (-20°F to 392°F)
 Class B 2,500 cycles / -29°C to 200°C
 (-20°F to 392°F)

ISO FE Type 3:
 Class B 2,500 cycles / -29°C to 200°C
 (-20°F to 392°F)

ISO FE Type 4:
 Class A 205 cycles / -50°C to 400°C
 (-58°F to 752°F)

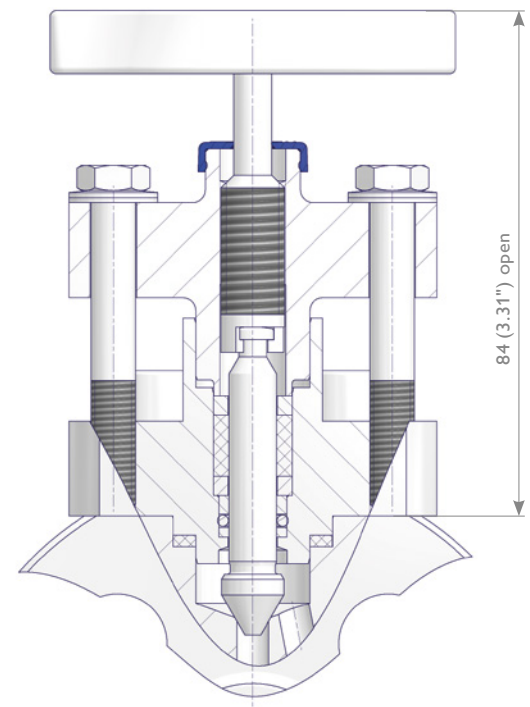

Picture shows ISO FE Type 1

Pressure-Temperature Rating – Needle Valve for Fugitive Emission Applications

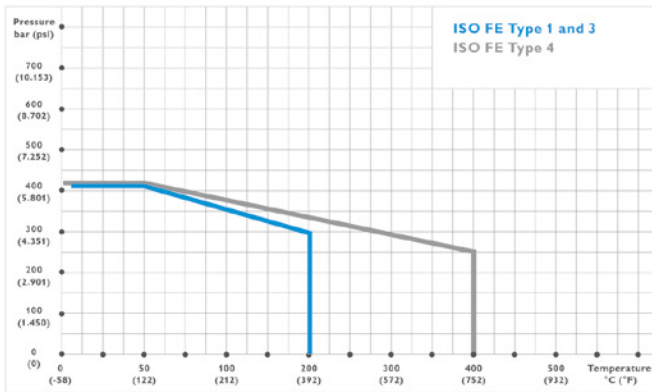

Above-mentioned Pressure-Temperature Rating is based on the standard material 316 stainless steel.

Other materials as shown on page 5 and 6 might have different Pressure-Temperature Ratings.

Stainless Steel Handwheel and 'Locking Plate' Design

The valves can be ordered with Stainless Steel Handwheel and Locking Plate Design, also including Padlock.

This design allows minimum handle movements and is ideal as protection against unauthorized closing of the valve. Against unauthorized opening of the valve, please choose anti-tamper head unit.

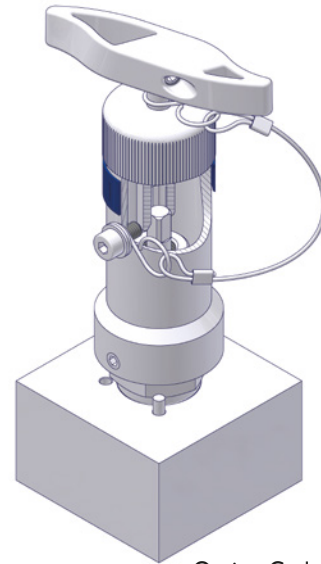

Option Code Q
Option Code R incl. Padlock

Anti-Tamper Head Unit

The valves are operated with a special Anti-Tamper Key (AT-Key), which fits exactly in the key guide. The valve can therefore only be operated with the AT-Key. In addition to this safety function, installing a padlock prevents the AT-Key being inserted into the key guide. Operating the valve is therefore no longer possible which protects your equipment against unauthorized opening and closing of the valve head units. The valve can be locked reliably in every position required. With the Interlocking System, the correct sequence of opening and closing of specific valves is ensured.

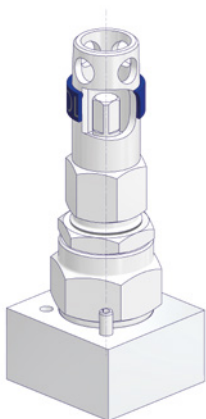

All Valve Head Units Anti-Tamper:
Option Code V



Part Number ATK-ES

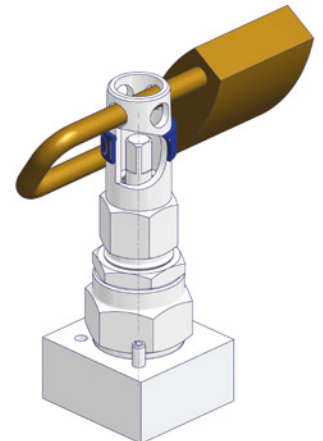

Incl. Padlock:
Option Code W or Y

Monoflanges I Options

Flange x Flange Types

- Dual Flange Style
- Wafer Style
- RD1 Style
- RFB Style

Dual Flange Style

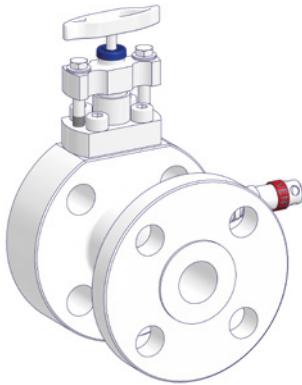

Wafer Style Option S

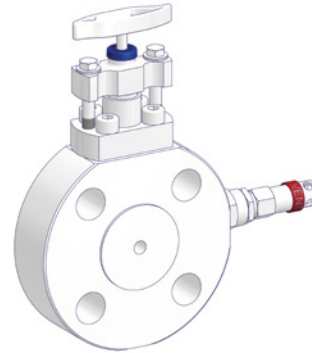

RD1 Style

For Direct Mounting of Transmitters acc. to EN 61518.

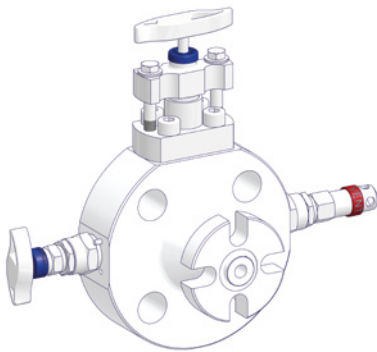

RFB Style

For Direct Mounting of Rosemount 2051/3051 Coplanar™ Pressure Transmitter.

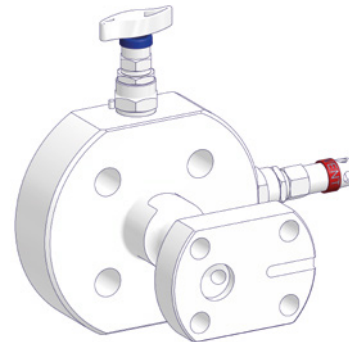

10 mm Bore Size

The max. allowable (Working) Pressure (PS) is limited to 420 bar (6,092 psi).

Process Monoflange

Double Block & Bleed (OS&Y / Needle / Needle)

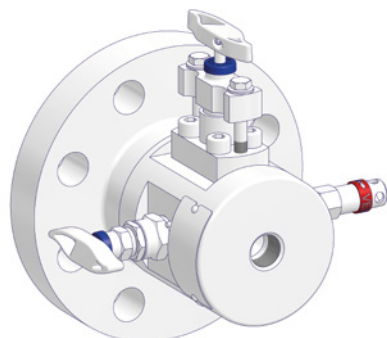

Instrument Monoflange

Double Block & Bleed (Needle / Needle / Needle)

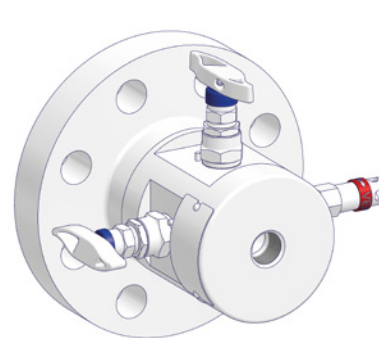

Dual Outlet Types for Direct Mounting to Horizontal or Vertical Pipelines

Vertical Pipeline – Radial Outlet
Process Monoflange (e.g. Block & Bleed) Swivel Gauge Adapter installed on outlet.

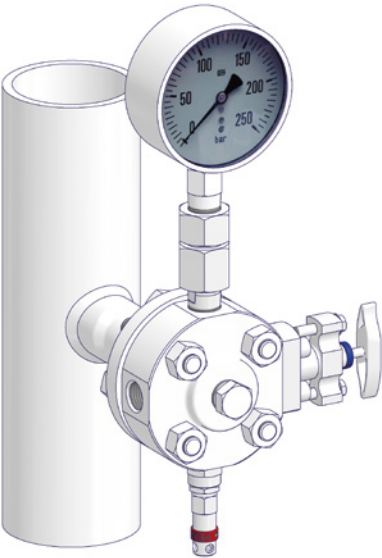

Horizontal Pipeline – Axial Outlet
Process Monoflange (e.g. Block & Bleed) Swivel Gauge Adapter installed on outlet.

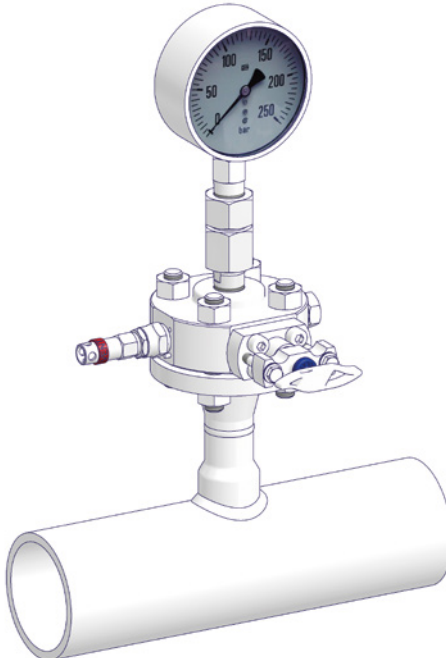

Vertical Pipeline – Radial Outlet
Instrument Monoflange (SM Type) with an Integral Swivel Gauge Adapter. For more information see Catalogue 'AS-3601 I Modular Mounting System'.



Horizontal Pipeline – Axial Outlet
Instrument Monoflange (SM Type) with an Integral Swivel Gauge Adapter. For more information see Catalogue 'AS-3601 I Modular Mounting System'.

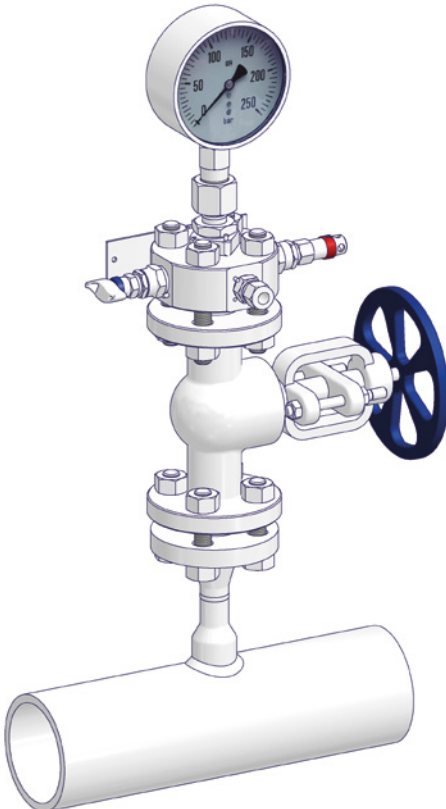

Monoflanges I Assemblies

Assemblies

There are various possibilities in using the Monoflange concept not only for Pressure Applications. The following pictures are showing two examples for Differential Pressure Assemblies – Flow and Level.

Flow Assembly – Consisting of:

- 1 x Process Monoflange Type V, e.g. DB&B with an Integrated 3 Valve Manifold (High Pressure Side +)
- 1 x Process Monoflange, e.g. DB&B (Low Pressure Side -)

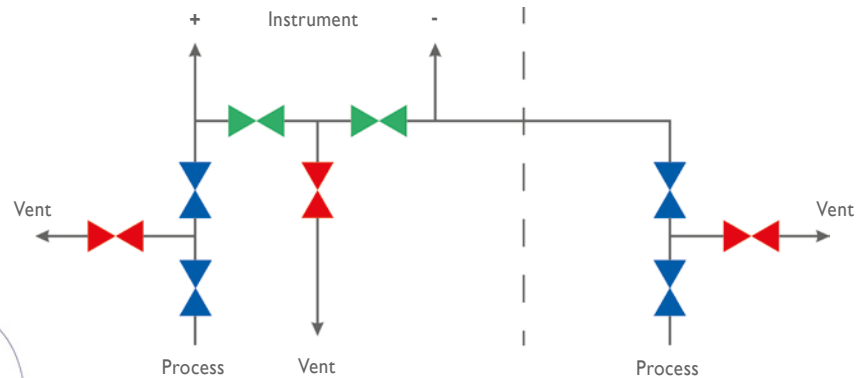
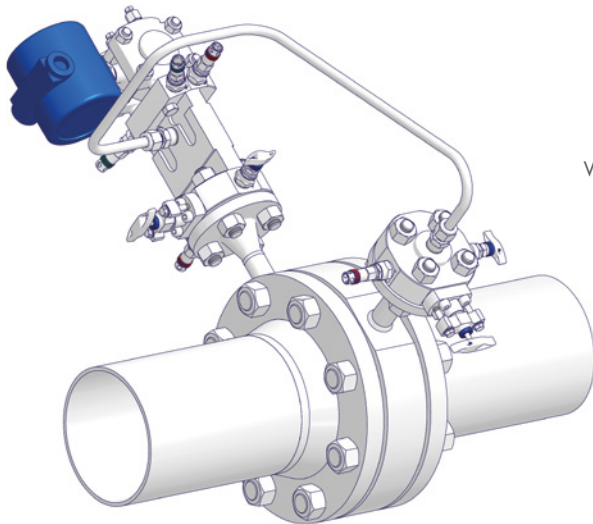

Level Assembly – Consisting of: (Wet / Dry Leg Installation)

- 1 x Process Monoflange Type V, e.g. DB&B with an Integrated 4 Valve Manifold (High Pressure Side +)
- 1 x Process Monoflange, e.g. DB&B (Low Pressure Side -)

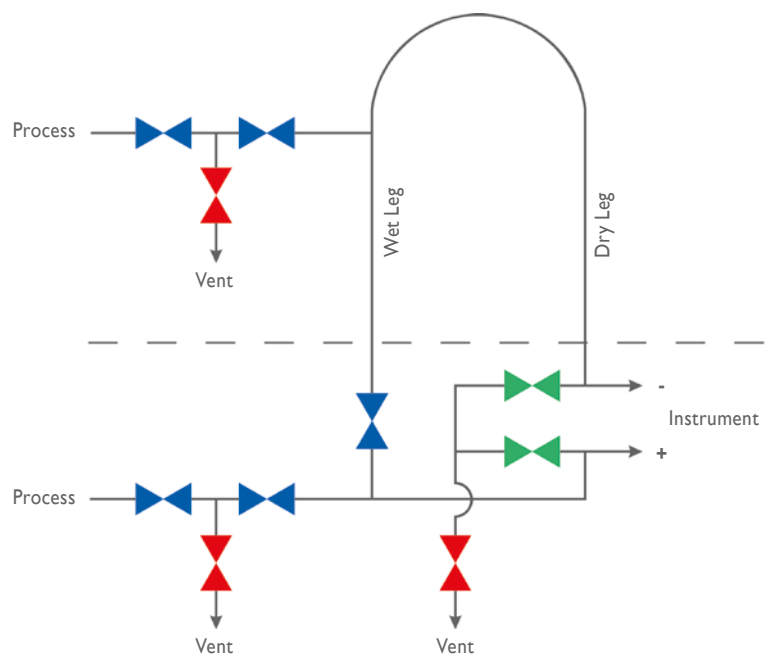
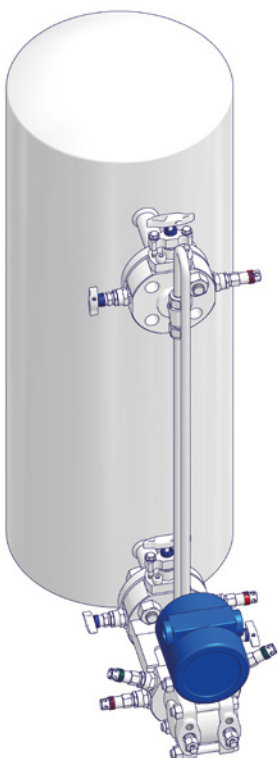

Process Monoflanges | Weights and Dimensions

Process Monoflanges – Weights and Dimensions

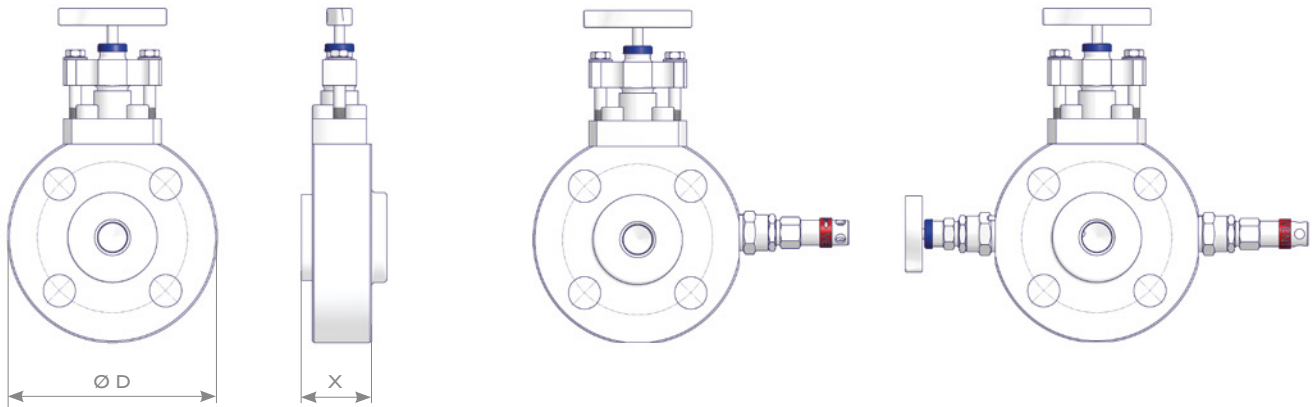

Flange x Thread

Flange Size (in)	Flange Class	Dimensions (mm)			Approx. Weight (kg)
		Ø D	X		
			Flange Facing		
			RF	RTJ	
1/2	150	98.6	36.6	–	2.5
1/2	300	98.6	36.6	40.6	2.6
1/2	600	98.6	41.4	40.6	2.6
1/2	900 / 1,500	120.7	41.4	41.4	3.5
1/2	2,500	133.4	41.4	41.4	4.3
3/4	150	98.6	36.6	–	2.6
3/4	300	117.3	36.6	41.4	3.5
3/4	600	117.3	41.4	41.4	3.5
3/4	900 / 1,500	130.0	41.4	41.4	4.1
3/4	2,500	139.7	41.4	41.4	4.8
1	150	108.0	36.6	41.4	3.0
1	300	124.0	36.6	41.4	3.9
1	600	124.0	41.4	41.4	3.9
1	900 / 1,500	149.3	41.4	41.4	5.1
1	2,500	158.8	42.4	42.4	6.1
1 1/2	150	127.0	36.6	41.4	4.1
1 1/2	300	155.4	36.6	41.4	6.0
1 1/2	600	155.4	41.4	41.4	6.0
1 1/2	900 / 1,500	177.8	41.4	41.4	7.4
1 1/2	2,500	203.2	51.4	52.9	11.4
2	150	152.4	36.6	41.4	5.4
2	300	165.1	36.6	42.9	6.4
2	600	165.1	41.4	42.9	6.9
2	900 / 1,500	215.9	45.4	46.9	12.0
2	2,500	235.0	58.4	59.9	17.5

Instrument Monoflanges | Weights and Dimensions

Instrument Monoflanges – Weights and Dimensions

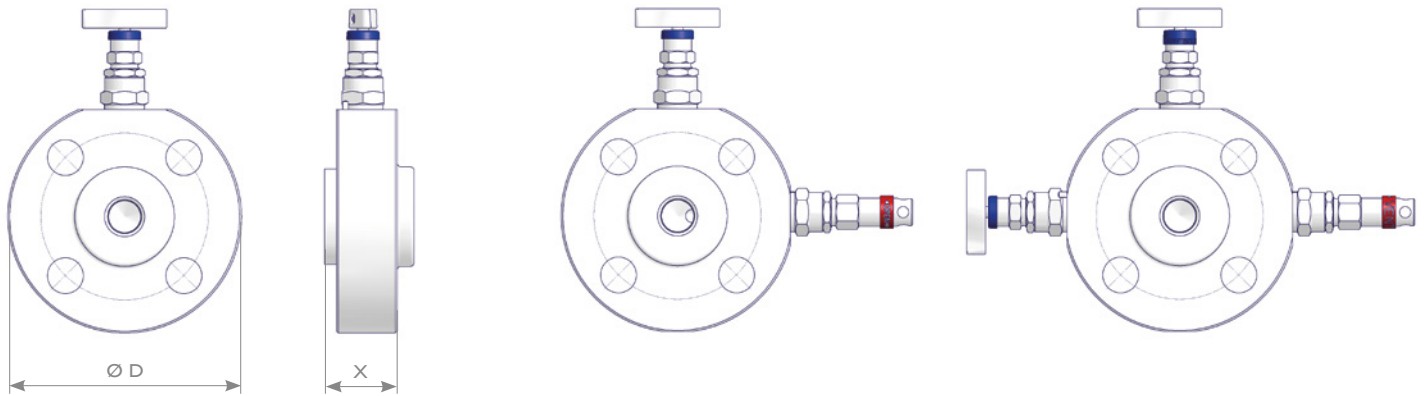

Flange x Thread

Flange Size (in)	Flange Class	Dimensions (mm)			Approx. Weight (kg)
		Ø D	X		
			Flange Face		
			RF x mm	RTJ x mm	
1/2	150	88.9	33.6	–	1.6
1/2	300	95.3	33.6	37.6	2.0
1/2	600	95.3	38.4	37.6	2.0
1/2	900 / 1,500	120.7	38.4	38.4	2.9
1/2	2,500	133.4	38.4	38.4	3.7
3/4	150	98.6	33.6	–	2.0
3/4	300	117.3	33.6	38.4	2.9
3/4	600	117.3	38.4	38.4	2.9
3/4	900 / 1,500	130.0	38.4	38.4	3.5
3/4	2,500	139.7	39.4	39.4	4.2
1	150	108.0	33.6	38.4	2.6
1	300	124.0	33.6	38.4	3.3
1	600	124.0	38.4	38.4	3.3
1	900 / 1,500	149.3	38.4	38.4	6.8
1	2,500	158.8	42.4	42.4	5.7
1 1/2	150	127.0	33.6	38.4	3.8
1 1/2	300	155.4	33.6	38.4	5.3
1 1/2	600	155.4	38.4	38.4	5.3
1 1/2	900 / 1,500	177.8	39.4	39.4	6.8
1 1/2	2,500	203.2	51.4	52.9	11.5
2	150	152.4	33.6	38.4	5.1
2	300	165.1	33.6	39.9	5.7
2	600	165.1	38.4	39.9	6.2
2	900 / 1,500	215.9	45.4	46.9	11.6
2	2,500	235.0	58.4	59.9	17.0

Monoflanges | Ordering Information

Ordering Information

				1	2	3	4	5	6	7	8	9	10	11	12	13	14
				M	G	B	-	N	F	E	L	N	4	-	S	C	
Monoflanges																	
Outlet Connection																	
Axial	Radial	Dual	Type														
MA	MB	MC	Block (OS&Y)														
MD	ME	MF	Block & Bleed (OS&Y / Needle)														
MG	MH	MJ	Double Block & Bleed (OS&Y / Needle / Needle)														
MK	ML	MM	Block (Needle)														
MN	MP	MQ	Block & Bleed (Needle / Needle)														
MR	MS	MT	Double Block & Bleed (Needle / Needle / Needle)														
M1			10 mm Bore I Block (OS&Y)														
M2			10 mm Bore I Block & Bleed (OS&Y / Needle)														
M3			10 mm Bore I Double Block & Bleed (OS&Y / Needle / Needle)														
M4			10 mm Bore I Block (Needle)														
M5			10 mm Bore I Block & Bleed (Needle / Needle)														
M6			10 mm Bore I Double Block & Bleed (Needle / Needle / Needle)														
Packing																	
A	PTFE	L	ISO FE Series Type 1														
B	Graphite	N	ISO FE Series Type 3														
W	Reinforced PTFE – TA-Luft	P	ISO FE Series Type 4														
Process Connection																	
ASME Flange						EN Flange											
NA	1/2" RF	NM	1 1/2" RTJ	QA	DN15 B1	QW	DN50 B1										
NC	1/2" RTJ	NN	2" RF	QD	DN15 C (tongue)	Q2	DN80 B1										
ND	3/4" RF	NQ	2" RTJ	QF	DN20 B1												
NF	3/4" RTJ	NR	2 1/2" RF	QL	DN25 B1												
NG	1" RF	NT	2 1/2" RTJ	QN	DN25 B2												
NJ	1" RTJ	NU	3" RF	QP	DN25 C (tongue)	API Flanges on request!											
NK	1 1/2" RF	NW	3" RTJ	QQ	DN25 D (groove)												
ASME Flange Class						EN Flange PN Designation											
A	150	D	900*	D	PN 40												
B	300	E	1,500	G	PN 160												
C	600	F	2,500	H	PN 250												
Outlet Connection																	
Thread Connection						Transmitter Interface											
LGQ	G 1/2 Female (Integral Swivel Gauge Adapter)					RD1	EN 61518 Type A (for Axial Outlet available only)										
LN4	1/2 NPT Female					RFB	For Rosemount 2051/3051 Coplanar™ Transmitter (for Axial Outlet available only)										
JN4	1/2 NPT Male																
For ASME Flange Connections on Axial Outlet use Designator of Process Connection. Dual Flange Style is Standard – Wafer Style see Options.																	
Body Material																	
C	A105	L	A350 LF2	V	Alloy 625 UNS N06625												
F	Duplex UNS S31803	M	Alloy 400 UNS N04400	D	Super Duplex UNS S32750												
H	Alloy C-276 UNS N10276	S	1.4401 / 1.4404 / 316 / 316L	B	6Mo UNS S31254												
Vent Connection																	
A	Without (Block Type only)			E	1/2 NPT Female												
C	1/4 NPT Female			F	1/2 NPT Female plugged												
D	1/4 NPT Female plugged																
Options																	
B	Oxygen Service			R	Stainless Steel Handwheel and Locking Plate Design incl. Padlock												
S	Wafer Style (Flange x Flange)			Q	Stainless Steel Handwheel and Locking Plate Design without Padlock												
M	Wetted Parts with 3.1 Certificate			V	All Valve Head Units Anti-Tamper lockable without Padlock												
				W	All Valve Head Units Anti-Tamper lockable incl. Padlock												
				Y	Vent Valve Head Units Anti-Tamper lockable incl. Padlock												

* Relevant for Flange Sizes $\geq 3"$ only. For Flange Sizes 1/2" to 2 1/2" Class 1,500 (Code E) to be used.

Wetted Parts according to above mentioned material list are supplied according to NACE MR0175/MR0103 and ISO 15156 (latest issue).

Note: Not every configuration which can be created in the ordering information is feasible / available.

VariAS-Blocks – Double Block & Bleed Types

VariAS-Blocks – Double Block & Bleed Types

The VariAS-Blocks – Double Block & Bleed Types are designed to replace conventional, multiple-valve installations. The VariAS-Blocks are forged, one-piece Double Block & Bleed assemblies for primary isolation of pressure take-offs, where the valve is directly mounted to the vessel or process pipe. Instruments may be directly mounted to the valve outlet or remote mounted with impulse pipe work.

Features two independently operable ball valves for isolation with an intermediate needle valve alternatively ball valve for venting.

Flange x Flange

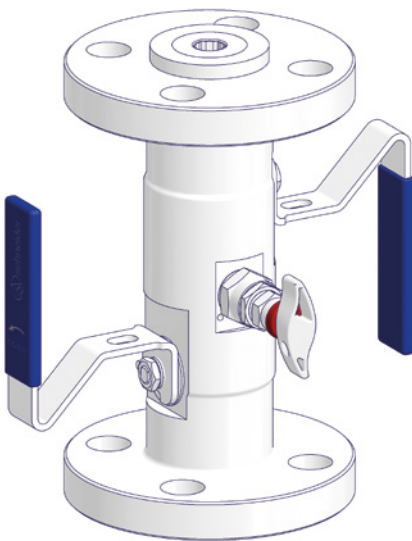

Double Isolate Ball Valve and Single Vent Needle Valve

Flange x Thread

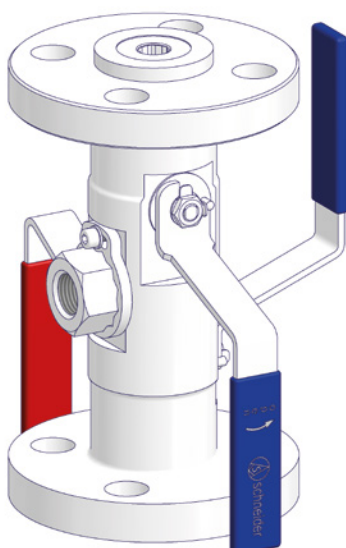
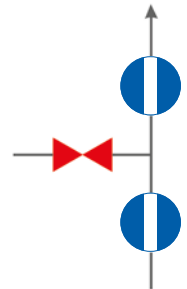
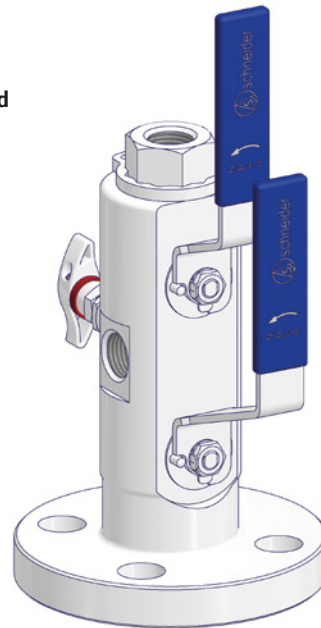

Double Isolate Ball Valve and Single Vent Ball Valve

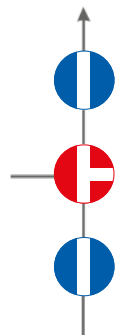
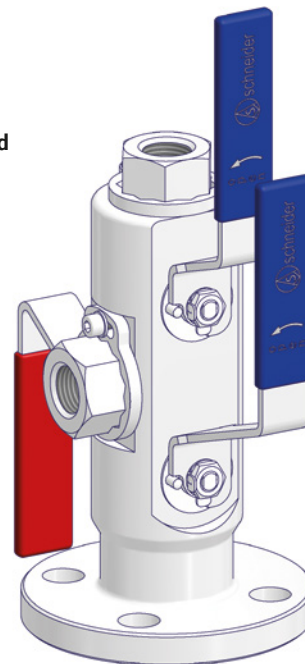

Body Material Options

Material Group	AS Material Designation	Material No.	Short Name	Equivalent UNS-No.	Material Grade acc. to ASTM
Carbon Steel	A105				A105
	LF2				LF2
Austenitic Stainless Steel	316 quadruple certified*	1.4401	X5CrNiMo17-12-2	S31600	316
		1.4404	X2CrNiMo17-12-2	S31603	316L
	6Mo	1.4547	X 1CrNiMoCuN20-18-7	S31254	
Austenitic-Ferritic Stainless Steel	Duplex	1.4462	X2CrNiMoN22-5-3	S31803	F51
	Superduplex	1.4410	X2CrNiMoN25.7.4	S32750	F53
		1.4501	X2CrNiMoCuWN25.7.4	S32760	F55
Nickel Based Alloys	Alloy 400	2.4360	NiCu30Fe	N04400	
	Alloy C-276	2.4819	NiMo 16 Cr 15 W	N10276	
	Alloy 625	2.4856	NiCr22Mo9Nb	N06625	
	Alloy 825	2.4858	NiCr21Mo	N08825	

* Quadruple certified means 316 / 316L / 1.4401 / 1.4404

Standard Features

Ball Bore Size	10 mm (0.39")	14 mm (0.55")	20 mm (0.79")
Needle Valve Bore Size	5 mm (0.197")	5 mm (0.197")	8 mm (0.315")
ASME B16.5 Flange Connections	1/2" to 2"	3/4" to 2"	1" to 3"

- Ball / Needle / Ball Design
- One-Piece Body
- Outlet Connection 1/2 NPT Female or Flange Connection acc. to Process Connection
- Vent Connection 1/2 NPT Female
- Fire Safe Tested acc. to ISO 10497 / API 607 – With Graphite Seals only
- Anti-Static Design
- Anti-Blowout Stems

Sour Gas Service:

Wetted parts according to a.m. material list are supplied as standard according to NACE MR0175/MR0103 and ISO 15156 / ISO 17945 (latest issue).

Pressure Test:

A shell test and a seat leakage test are performed at 1.5 times the max. allowable (Working) Pressure (PS) acc. to EN 12266-1 – P10, P11 and P12 respectively MSS-SP61 (and complies also with ASME B31.1 and B31.3) at every standard AS-Schneider VariAS-Block → 100% Pressure Tested!

Certification:

Certified Mill Test Report (CMTR) as inspection certificate 3.1 acc. to EN 10 204 for valve body material and pressure test available on request.

The manifolds can be provided by default with a

- CRN Certificate
- EAC Certificate – Manifolds are marked with EAC

Optional Features

- API Flange Connections (up to 689 bar [10,000 psi])
- EN 1092-1 Flange Connections
- Ball / Ball / Ball Design
- Ball / Needle Design
- Ball / Ball Design
- Metal Seated Ball Valve for 10 mm Bore Size
- Anti-Tamper Head Units
- Swivel Gauge Connectors – See also Accessories on Page 26
- Pressure Tested according to API 598
- Wake Frequency Calculation for Injection or Sampling Applications
- Hydrogen Service

Fugitive Emission Application:

For Fugitive Emission Applications AS-Schneider is providing TA-Luft and ISO 15848 solutions. For more details please contact the factory.

Oxygen and Hydrogen Service:

On request.

If you don't find your options in this catalogue, please contact the factory.

Standard Valve Designs for VariAS-Blocks

Ball Valves – Bore Size 10 mm (0.39")

Standard Design – Stem Seal: Packing

Features

- Floating Ball Design
- Ball Valve Seat: Reinforced PTFE or PEEK
- Ball Valve Seats are totally enclosed in seat carrier
- Seat Seals: FKM, RGD resistant O-Ring and Graphite or PTFE
- Stem Seal: Standard Packing in PTFE and Graphite
- Max. allowable (Working) Pressure (PS): 420 bar (6,092 psi)
- Anti-Blowout Stem Design
- Anti-Static Design
- Fire Safe Tested acc. to ISO 10497 / API 607
 - With Graphite Packing only
- All Non-wetted Parts in 316 Stainless Steel
- Lockable Handle with Color Coded Handle Grip
 - Isolate BLUE | Vent RED

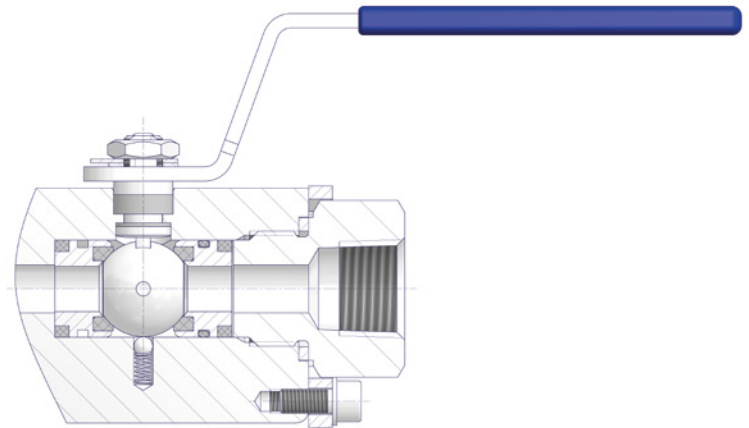

Components	Carbon Steel	Stainless Steel	Exotic Alloys					
	Material / Material No.							
Body	A 105 resp. LF2	316 / 316L	Alloy 400	Alloy C-276	Duplex	UNS S32750	Alloy 625	6Mo
Body End Connector								
Ball	316 / 316L	316 / 316L	Alloy 400	Alloy C-276	Duplex	UNS S32750	Alloy 625	6Mo
Stem								
Seat Carrier								
Ball Seat	Reinforced PTFE or PEEK							
Carrier Seals	FKM / Graphite or FKM / PTFE							
Primary Stem Seal	Reinforced PTFE							
Packing	PTFE or Graphite							
Gland	316							
Locking Plate	316							
Handle	316							
Handle Grip	Vinyl							
Stop Pin	A4							

Wetted components listed in **bold**.

Metal Seated Ball Valves – Bore Size 10 mm (0.39")

Standard Design – Stem Seal: Packing

Features

- Floating Ball Design
- Ball and Valve Seats are coated with Hardalloy and Carbide Compounds
- Seat Seals: FKM RGD resistant O-Ring and Graphite
- Stem Seal: Packing in Graphite
- Max. allowable (Working) Pressure (PS): 420 bar (6,092 psi)
- Fully rated up to 200°C (392°F; according to ASME B16.34)
- Spring-loaded Seats to ensure low operating torques and to compensate temperature changes
- Anti-Blowout Stem Design
- Anti-Static Design
- Fire Safe Tested acc. to ISO 10497 / API 607
- All Non-wetted Parts in 316 Stainless Steel
- Lockable Handle with Color Coded Handle Grip
 - Isolate BLUE | Vent RED

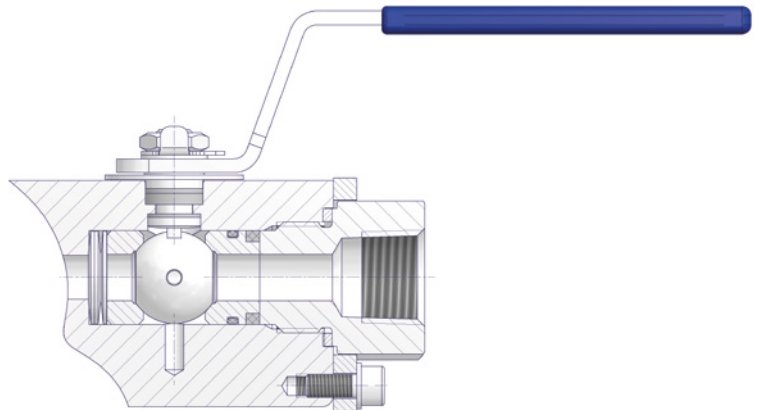

Components	Carbon Steel	Stainless Steel
	Material / Material No.	
Body	A 105 resp. LF2	316 / 316L
Body End Connector		
Stem	316 / 316L	
Ball	316	
Ball Seat	TCC Coated	
Seat Seals	FKM / Graphite	
Primary Stem Seal	Reinforced PTFE	
Packing	Graphite	
Beleville Springs	Inconel 718	
Gland	316	
Locking Plate	316	
Handle	316	
Handle Grip	Vinyl	
Stop Pin	A4	

Wetted components listed in **bold**.

Standard Valve Designs for VariAS-Blocks

Ball Valves – Bore Size 14 mm (0.55") and 20 mm (0.79")

Standard Design – Stem Seal: Packing

Features

- Floating Ball Design
- Ball Valve Seat: PEEK or Reinforced PTFE
- Self Venting Ball Seats
- Stem Seal: Standard Packing in PTFE and Graphite
- Max. allowable (Working) Pressure (PS):
420 bar (6,092 psi) with PEEK Seats and
150 bar (2,175 psi) with Reinforced PTFE Seats
- Metal Sealing between Body and End Connector.
Additional O-Ring at the Body End Connector to protect
Threads from the Environment.
- Anti-Blowout Stem Design
- Anti-Static Design
- Fire Safe Tested acc. to ISO 10497 / API 607
– With Graphite Packing only
- All Non-wetted Parts in 316 Stainless Steel
- Lockable Handle with Color Coded Handle Grip
– Isolate **BLUE** | Vent **RED**

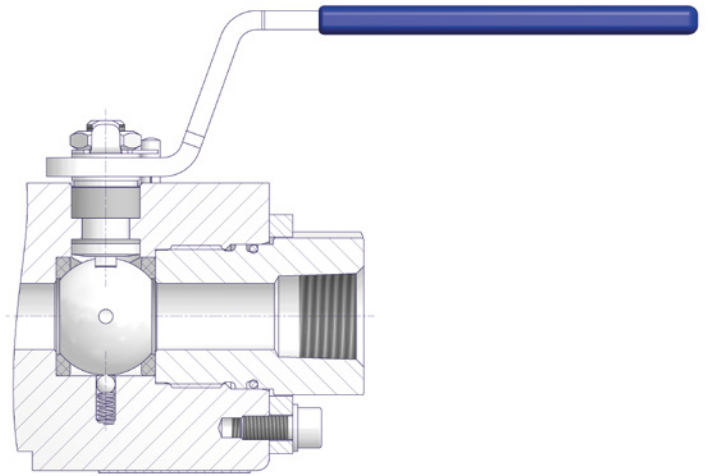

Standard Valve Designs for VariAS-Blocks

Ball Valves – Bore Size 14 mm (0.55") and 20 mm (0.79")

Materials of Construction

Components	Carbon Steel	Stainless Steel	Exotic Alloys					
	Material / Material No.							
Body	A 105 resp. LF2	316 / 316L	Alloy 400	Alloy C-276	Duplex	UNS S32750	Alloy 625	6Mo
Body End Connector								
Ball	316 / 316L							
Stem	316 / 316L							
Ball Seat	Reinforced PTFE or PEEK							
Primary Stem Seal	Reinforced PTFE							
Packing	PTFE or Graphite							
O-Ring	FKM							
Gland	316							
Locking Plate	316							
Handle	316							
Handle Grip	Vinyl							
Stop Pin	A4							

Wetted components listed in bold.

Standard Needle Valves

Screwed Bonnet – Needle Seal: Packing

Features

- Integral Valve Seat – Metal to metal seated
- Non-rotating Needle
- External Stem Thread – Packing below stem threads.
Stem Threads are protected from process media (non-wetted).
- Stem with Cold Rolled Threads
- Blow-out Proof Needle
- Back Seat – Metal to metal secondary needle seal
- Lock Pin – Eliminates unauthorized removal of the bonnet
- Color Coded Dust Cap for operating thread protection (see page 6)
- Needle Seal: Standard Packing in PTFE and Graphite
- Max. allowable (Working) Pressure (PS): 420 bar (6,092 psi)
- Anti-Tamper Valve Head Options and Stainless Steel Handwheel available (see Page 9)
- Materials of Construction (see Page 6)
- All Non-wetted Parts in 316 Stainless Steel

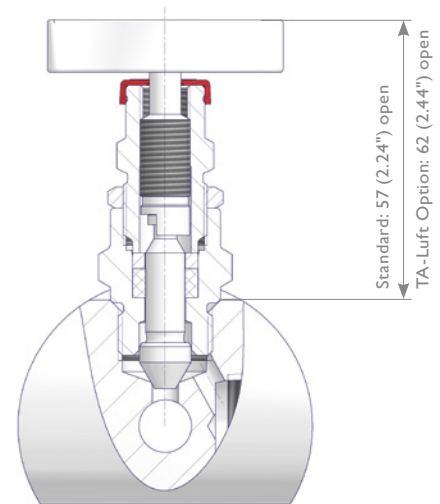

Fugitive Emission Application Designs for VariAS-Blocks

Valves acc. to ISO 15848 / TA-Luft 2021

We can offer the full range of our VariAS-Block Series tested and certified according to ISO 15848-1. These valves are designed to reduce fugitive emissions for environmental protection.

- Tested and applicable for use up to 200°C (392°F)
- Production Test according to ISO 15848-2 available on request

YOUR BENEFITS:

- ✓ Also Needle Valves are tested and certified according to ISO 15848-1.
- ✓ Graphite Packed VariAS-Blocks according to ISO 15848-1 meet also the requirements for Fire Safe according to ISO10497 / API 607.
- ✓ ISO 15848-1 Valves also comply with the requirements of TA Luft 2021.
- ✓ Reliability due to Type Testing and Certification by third party inspection.

Needle Valves acc. to ISO 15848 / TA-Luft 2021

Screwed Bonnet – Type 1 O-Ring Needle Seal + Graphite Packing
Type 3 PTFE Packing
Type 4 – Graphite packing

Features

- Integral Valve Seat – Metal to metal seated
- Non-rotating Needle
- External Stem Thread – Packing below stem threads. Stem threads are protected from process media (non-wetted).
- Stem with Cold Rolled Threads
- Blow-out Proof Needle
- Back Seat – Metal to metal secondary needle seal
- Lock Pin – Eliminates unauthorized removal of the bonnet
- Color Coded Dust Cap for operating thread protection (see page 6)
- Needle Seal:
 - Standard Packing in PTFE or Graphite plus FKM O-Ring Needle Seal – RGD resistant (RGD = Rapid Gas Decompression)
- Max. allowable (Working) Pressure (PS): 420 bar (6,092 psi)
- Anti-Tamper Valve Head Options available on request
- All Non-wetted Parts in 316 Stainless Steel
- Types also comply with the requirements of TA-Luft 2021

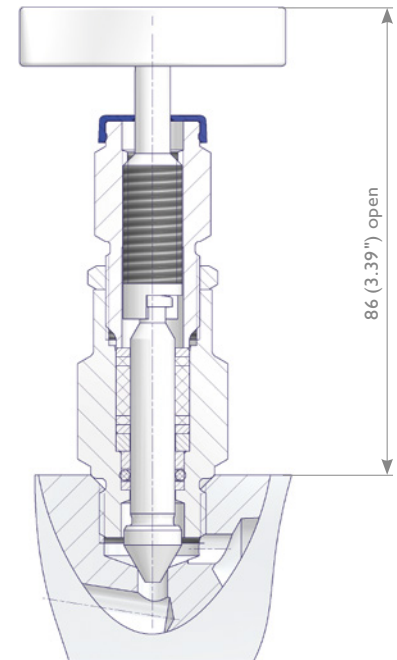

Picture shows ISO FE Type 1

Fugitive Emission Application Designs for VariAS-Blocks

ISO FE Performance Data

Tightness Class for VariAS-Blocks at Room Temperature (RT) (-29°C to 40°C [-20°F to 104°F]) Double Block & Bleed (Ball / Needle / Ball)

Ball Seat	Packing Ball Valve	Packing Needle Valve	Tightness Class		
			C01 205 Cycles*	C02 1,500 Cycles	C03 2,500 Cycles
Reinforced PTFE	PTFE	PTFE / Reinforced PTFE	Class A	Class A	Class B
	Graphite	Graphite + FKM O-Ring		Class B	
PEEK	PTFE	PTFE / Reinforced PTFE		Class A	Class B
	Graphite	Graphite + FKM O-Ring		Class B	
PEEK					
Metal Seated	Graphite	Graphite + FKM O-Ring		Class B	

* Several Stem Seals meet the requirement of ISO 15848-1, Edition 2006. These are more stringent than these of the current Edition 2015:

- Tightness values for Class A was reduced by the factor 10.
- Numbers of mechanical cycles for Class CO1 was reduced from 500 to 205.

Note: The above mentioned table is only valid for Double Block & Bleed Valves (Ball / Needle / Ball). For other types please contact the factory.

Tightness Class for VariAS-Blocks at 200°C (RT to 200°C [-RT to 392°F]) Double Block & Bleed (Ball / Needle / Ball)

Ball Seat	Packing Ball Valve	Packing Needle Valve	Tightness Class			
			C01 205 Cycles*	C02 1,500 Cycles	C03 2,500 Cycles	
Reinforced PTFE	PTFE	PTFE / Reinforced PTFE	Class B		On request	
	Graphite	Graphite + FKM O-Ring		Class B		
PEEK	PTFE	PTFE / Reinforced PTFE		Class B		
	Graphite	Graphite + FKM O-Ring		Class B		
Metal Seated	Graphite	Graphite + FKM O-Ring		Class B		

* Several Stem Seals meet the requirement of ISO 15848-1, Edition 2006. These are more stringent than these of the current Edition 2015:

- Tightness values for Class A was reduced by the factor 10.
- Numbers of mechanical cycles for Class CO1 was reduced from 500 to 205.

Note: The above mentioned table is only valid for Double Block & Bleed Valves (Ball / Needle / Ball). For other types please contact the factory.

VariAS-Block Options and Related Types

Block & Bleed Types

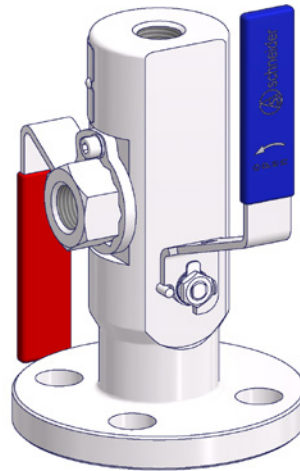

Note: Flange x Flange Types are not illustrated.

Ball Valve Manifolds (see catalog AS-1901)

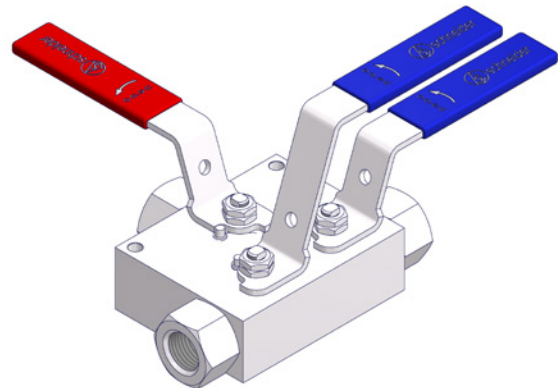
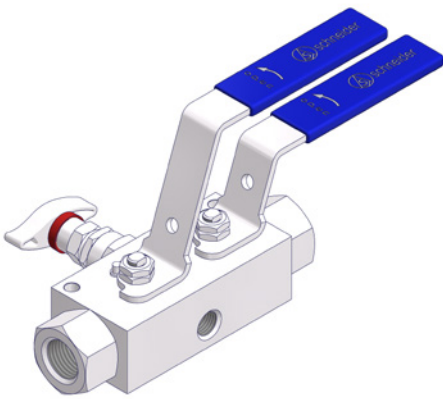

VariAS-Block for Injection and Sampling Applications

VariAS-Block for Injection and Sampling Applications

All options and configurations shown within the standard VariAS-Block Range can be offered by the addition of a customized injection probe respectively sampling probe which extends from the pipe flange into the process stream. The probe is designed as a one piece solution with a fine-turned surface to optimize the wake frequency behavior and provide utmost stability. The probe lengths must be specified by the customer. The probe O.D. is 25 mm. Wake frequency calculation and support collar on request.

VariAS-Block for Sampling Applications

Option 1

This design has been developed to remove a sample directly from the process stream at full system pressure.

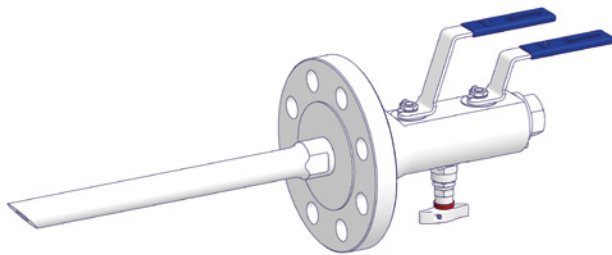

VariAS-Block for Injection Applications

Option V

This design has been developed to inject directly into the process stream at full system pressure. The integral check valve eliminates the risk of back flow out of the process stream during the injection. Available on both flanged and threaded connections.

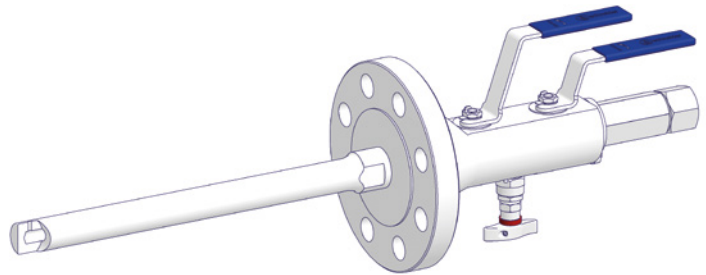

Installed Injection VariAS-Block incl. Check Valve

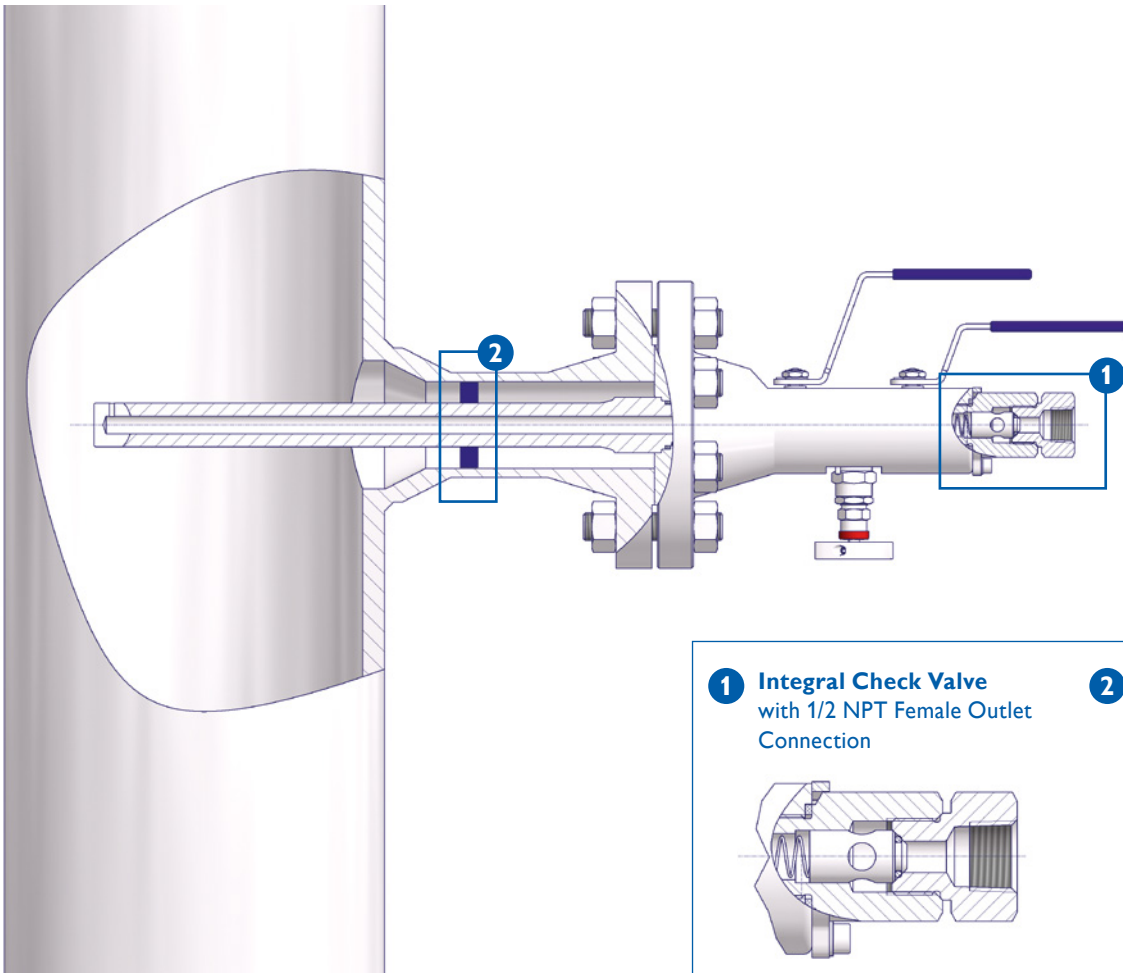

VariAS-Blocks I Weights and Dimensions

VariAS-Blocks – Weights and Dimensions

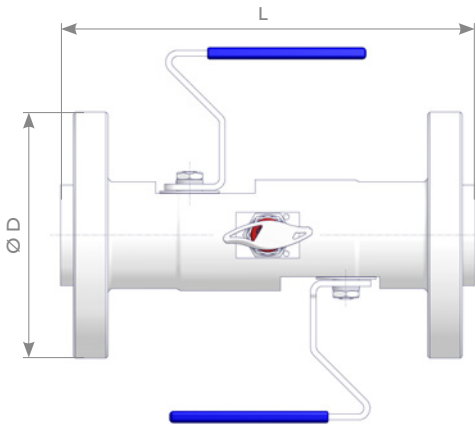

Flange x Flange

Flange Size (in)	Flange Class	Ø D (mm)	Bore Size 10 mm (0.39")			Bore Size 14 mm (0.55")			Bore Size 20 mm (0.79")		
			L (mm)		Approx. Weight (kg)	L (mm)		Approx. Weight (kg)	L (mm)		Approx. Weight (kg)
			Flange Facing RF	RTJ		Flange Facing RF	RTJ		Flange Facing RF	RTJ	
1/2	150	88.9	199.2		3						
	300	95.3	199.2	207.2	4						
	600	95.3	208.8	207.2	4						
	900 / 1,500	120.6	208.8	208.8	6						
	2,500	133.4	208.8	208.8	8						
3/4	150	98.6	199.2		4	210.0		5			
	300	117.3	199.2	208.8	5	210.0	242.0	7			
	600	117.3	208.8	208.8	5	242.0	242.0	7			
	900 / 1,500	130.0	208.8	208.8	7	280.0	280.0	10			
	2,500	139.7	240.8	240.8	10	280.0	280.0	12			
1	150	108.0	199.2	208.8	5	210.0	210.0	6	200.0		7
	300	124.0	199.2	208.8	6	210.0	242.0	7	200.0	200.0	9
	600	124.0	208.8	208.8	6	242.0	242.0	8	200.0	200.0	9
	900 / 1,500	149.3	240.8	240.8	10	280.0	280.0	12	287.0	287.0	14
	2,500	158.8	240.8	240.8	14	280.0	280.0	15	287.0	287.0	17
1 1/2	150	127.0	199.2	208.8	6	210.0	210.0	8	200.0	200.0	10
	300	155.4	231.2	240.8	9	242.0	242.0	11	200.0	200.0	12
	600	155.4	240.8	240.8	10	242.0	242.0	12	237.0	237.0	13
	900 / 1,500	177.8	240.8	240.8	16	242.0	242.0	16	237.0	237.0	18
	2,500	203.2	265.8	268.8	27	280.0	280.0	26	287.0	287.0	29
2	150	152.4	231.2	240.8	9	242.0	242.0	11	200.0	200.0	12
	300	165.1	231.2	243.8	12	242.0	242.0	12	200.0	200.0	14
	600	165.1	240.8	243.8	13	242.0	242.0	14	200.0	200.0	14
	900 / 1,500	215.9	265.8	268.8	28	280.0	280.0	27	237.0	237.0	27
	2,500	235.0	265.8	268.8	40	280.0	280.0	37	287.0	287.0	39
2 1/2	150	177.8							200.0	200.0	16
	300	190.5							200.0	200.0	18
	600	190.5							237.0	237.0	20
	900 / 1,500	244.5							287.0	287.0	38
	2,500	266.7							381.0	386.0	58
3	150	190.5							200.0	200.0	18
	300	209.5							200.0	200.0	22
	600	209.5							237.0	237.0	25
	900	241.3							287.0	287.0	37
	1,500	266.7							335.0	335.0	52
	2,500	304.8							401.0	406.0	85

VariAS-Blocks I Weights and Dimensions

VariAS-Blocks – Weights and Dimensions

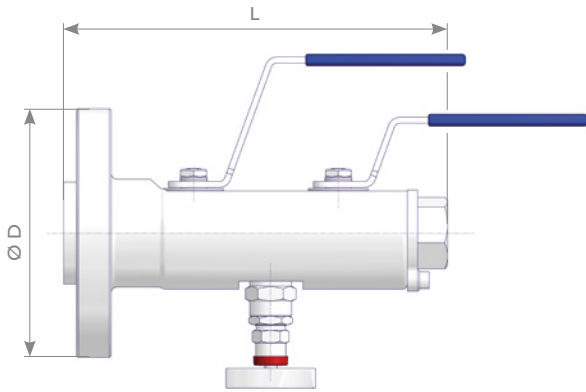

Lockable Valves – Option W

All Valves with Option W (Lockable Valves) have Secondary Isolation Valve on opposite side of Primary Isolation Valve.

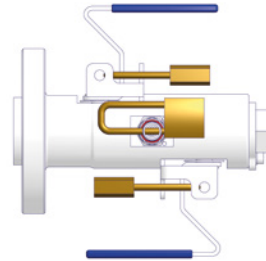

Flange x Thread

Flange Size (in)	Flange Class	Ø D (mm)	Bore Size 10 mm (0.39")			Bore Size 14 mm (0.55")			Bore Size 20 mm (0.79")		
			L (mm)		Approx. Weight (kg)	L (mm)		Approx. Weight (kg)	L (mm)		Approx. Weight (kg)
			Flange Facing RF	RTJ		Flange Facing RF	RTJ		Flange Facing RF	RTJ	
1/2	150	88.9	187.2		3						
	300	95.3	187.2	191.2	3						
	600	95.3	192.0	191.2	3						
	900 / 1,500	120.6	192.0	192.0	4						
	2,500	133.4	192.0	192.0	5						
3/4	150	98.6	187.2		3	192.5		5			
	300	117.3	187.2	192.0	4	192.5	208.5	5			
	600	117.3	192.0	192.0	4	208.5	208.5	6			
	900 / 1,500	130.0	192.0	192.0	5	227.5	227.5	7			
	2,500	139.7	208.0	208.0	6	227.5	227.5	8			
1	150	108.0	192.0	192.0	4	192.5	192.5	5	207.0		8
	300	124.0	192.0	192.0	4	192.5	208.5	6	207.0	207.0	8
	600	124.0	192.0	192.0	4	208.5	208.5	6	207.0	207.0	8
	900 / 1,500	149.3	208.0	208.0	6	227.5	227.5	8	242.0	242.0	11
	2,500	158.8	208.0	208.0	8	227.5	227.5	10	242.0	242.0	12
1 1/2	150	127.0	192.0	192.0	5	192.5	192.5	6	207.0	207.0	9
	300	155.4	208.0	208.0	6	208.5	208.5	8	207.0	207.0	10
	600	155.4	208.0	208.0	7	208.5	208.5	8	223.0	223.0	10
	900 / 1,500	177.8	208.0	208.0	9	208.5	208.5	10	223.0	223.0	13
	2,500	203.2	224.0	224.0	15	227.5	227.5	15	242.0	242.0	18
2	150	152.4	208.0	208.0	6	208.5	208.5	8	207.0	207.0	10
	300	165.1	209.5	209.5	7	208.5	208.5	8	207.0	207.0	11
	600	165.1	209.5	209.5	8	208.5	208.5	9	207.0	207.0	11
	900 / 1,500	215.9	224.0	224.0	15	227.5	227.5	16	223.0	223.0	17
	2,500	235.0	224.0	224.0	21	227.5	227.5	21	242.0	242.0	23
2 1/2	150	177.8							207.0	207.0	12
	300	190.5							207.0	207.0	13
	600	190.5							207.0	207.0	13
	900 / 1,500	244.5							242.0	242.0	23
	2,500	266.7							284.0	284.0	32
3	150	190.5							207.0	207.0	13
	300	209.5							207.0	207.0	15
	600	209.5							223.0	223.0	17
	900	241.3							242.0	242.0	20
	1,500	266.7							242.0	242.0	28
	2,500	304.8							284.0	284.0	45

Pressure Ratings, Codes and Specifications for VariAS-Blocks

Pressure-Temperature Rating – Soft Seated Ball Valve 10 mm (0.39") Bore Size

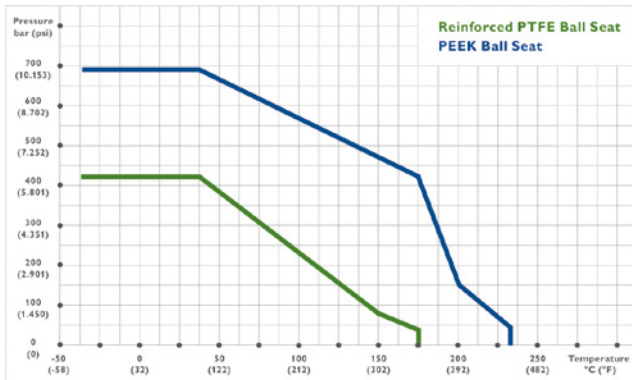

Pressure-Temperature Rating – Soft Seated Ball Valve 14 mm (0.55") Bore Size and 20 mm (0.79") Bore Size

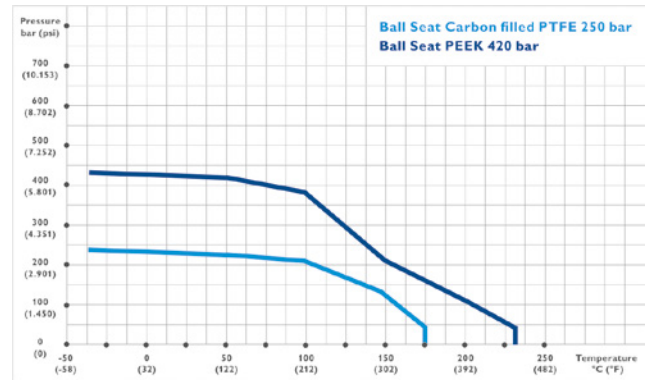

Pressure-Temperature Rating – Metal Seated Ball Valve (10 mm [0.39"] Bore Size)

The Valve is fully rated according to ASME B16.34 up to 200°C (392°F).

Pressure-Temperature Rating – Fugitive Emission Option according to ISO 15848-1

The above mentioned Pressure-Temperature Ratings are limited to max. 200°C (392°F) and 420 bar (6,092 psi).

Pressure-Temperature Rating – Needle Valve

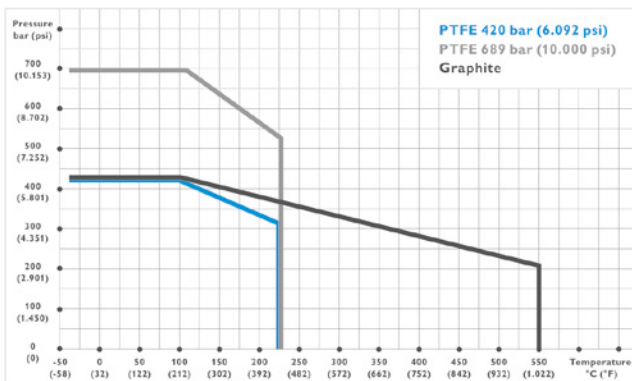

Note: All above mentioned Pressure-Temperature Ratings represent the max. allowable (Working) Pressure (PS). Note that these can be derated by the flange size or body material.

Pressure-Temperature Ratings are based on the standard material 316 stainless steel.

Other materials as shown on page 17, 18 and 21 might have different Pressure-Temperature Ratings.

Codes and Specifications

- | | | | |
|-------------------------|---|--------------|---|
| • ASME B31.3 | Process Piping Specification for Pipeline Valves | • MSS SP-61 | Pressure Testing of Valves |
| • ASME B16.34 | Valves – Flanged, Threaded and Welding End | • MSS SP-99 | Instrument Valves |
| • ASME B16.5 | Pipe Flanges and Flanged Fittings | • EN 1092-1 | Flanges and their joints - Circular flanges for pipes, valves, fittings and accessories, PN designated - Part 1: Steel flanges |
| • NACE MR0175/ISO 15156 | Petroleum and Natural Gas Industries – Materials for use in H2S-containing Environments in Oil and Gas Production | • EN 16668 | Industrial valves - Requirements and testing for metallic valves as pressure accessories |
| • API 598 | Valve Inspection and Testing | • EN 13445 | Unfired pressure vessels: Part 1: General, Part 2: Materials |
| • ISO 5208 | Industrial Valves – Pressure Testing of Metallic Valves | • EN 15848-1 | Industrial valves - Measurement, test and qualification procedures for fugitive emissions - Part 1: Classification system and qualification procedures for type testing of valves (ISO 15848-1:2015 + Amd.1:2017) |
| • API 607/ISO 10497 | Fire Test for Soft-Seated Quarter Turn Valves Testing of Valves. Fire Type-testing Requirements | | |
| • MSS SP-25 | Standard Marking System for Valves, Fittings, Flanges, and Unions | | |

Metal Seated High Pressure DBB Valve

API 6A VariAS-Blocks are available in 10,000 psi and 15,000 psi rating

Features

- Design acc. to API 6A
- Ball Bore Size:
10,000 psi: 10mm (0.39") or 14mm (0,55")
15,000 psi: 14mm (0,55")
- 3 Piece, Trunnion Ball Design
- Seat and Ball Surfaces coated with Nickel Hard Alloy and Tungsten Carbide
- Dynamic and Static Seals: PTFE-Lip Seal and Graphite (Elastomer-free)
- Pressure rating:
10,000 psi /15,000 psi at -50°C up to +120°C
- Drain Ports optional
- Weld Overlay (Cladding) optional
- Anti-Static and Anti-Blowout Stem Design
- Fire Safe Design
- All non-wetted parts in 316 Stainless Steel
- Lockable Lever
- API 6A PR2 and API 6A PSL 3G tested
- ISO 15848-1 Fugitive Emission Tightness Class A
- TA-Luft 2021 compliant

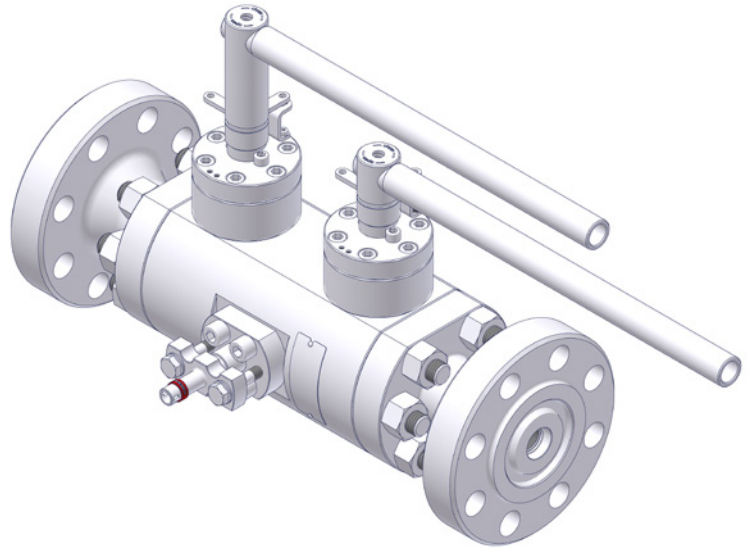

Materials of construction

Main Components	Duplex	Steel
Body	ASTM A182 F51	ASTM A694 F60
Closure	ASTM A182 F51	ASTM A694 F60
Bonnet	ASTM A182 F51	ASTM A694 F60
Ball	ASTM A479 UNS S31803	
Ball Seat	Nickel Hard Alloy and Tungsten Carbide Coating	
Stem	ASTM A479 UNS S31803	
Dynamic Seals (Seat and Stem) and Static Seals (Body Seals)	Primary Seal: PTFE-Lip Seal with PEEK backup ring and Elgiloy Springs Secondary Seal: Graphite	

DVT (TAT) — VariAS-Blocks | MES C SPE 77/300

DBB Valve - Soft Seated – Bore Size 10mm (0.39”), 14mm (0.55”), 20mm (0.79”)

Features

- Design acc. to SHELL MES C SPE 77/170
- Approved Performance Validation acc. to
 - SHELL MES C SPE 77/300, APPENDIX C (DVT)
 - PETRONAS PTS 12.32.07 (PAT)
- One piece body
- Uni-Directional Floating Ball Design with Spring Energized PEEK Seats
- Seat Seals: FKM RGD resistant O-Ring and Graphite
- Stem Seal: FKM RGD resistant O-Ring and Graphite
- Flange Sizes: ½” up to 2”
- ASME B16.34 Pressure Class: 150 up to 2500
- Qualified Temperature range: -50°C up to +150°C
- Anti-Static and Anti-Blowout Stem Design
- Fire Safe Tested acc. to ISO 10497 / API 607
- All non-wetted parts in 316 Stainless Steel

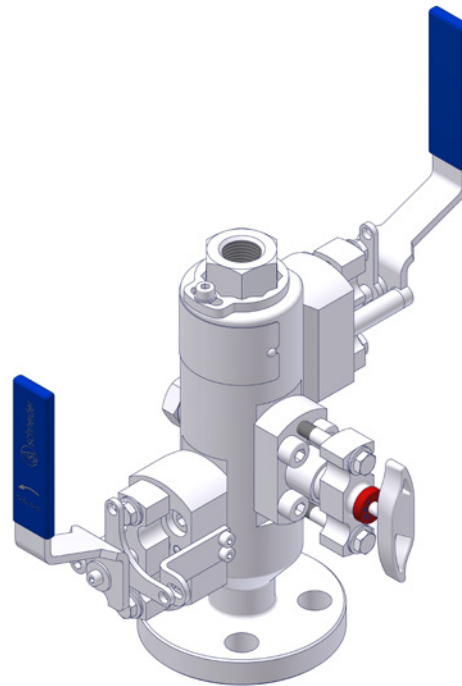

Materials of construction

Main Components	Carbon Steel	Stainless Steel	Duplex
Body	A105 resp. LF2	316/316L	F51
Body End Connector	A105 resp. LF2	316/316L	S31803
Bonnet	A105 resp. LF2	316/316L	31803
Ball	316/316L	316/316L	31803
Stem	316/316L		31803
Seat Carrier	316/316L		31803
Disc Spring for Valve Seat	Inconel 718		
Primary Seal	Reinforced PTFE		
Dynamic seals (Sea and Stem) and Static seals (Body Seals)	Primary Seal: FKM RGD resistant O-Ring Secondary Seal: Graphite		

DBB Valve - Soft Seated – Bore Size 10mm (0.39")

Features

- Design acc. to SHELL MESC SPE 77/170
- Approved Performance Validation acc. to SHELL MESC SPE 77/300, APPENDIX C (DVT) PETRONAS PTS 12.32.07 (PAT)
- One piece body
- Uni-Directional Floating Ball Design with Spring Energized Metal Seats
- Seat and Ball Surfaces coated with Nickel Hard Alloy and Tungsten Carbide
- Seat Seals: Graphite
- Stem Seal: Graphite
- Flange Sizes: 1/2" up to 2"
- Qualified Pressure Classes:
Class 150 – 600
Class 900 – 2500 under application
- Qualified Temperature range: Ambient up to +300°C
- Anti-Blowout Stem Design
- Fire Safe Tested acc. to ISO 10497 / API 607
- All non-wetted parts in 316 Stainless Steel

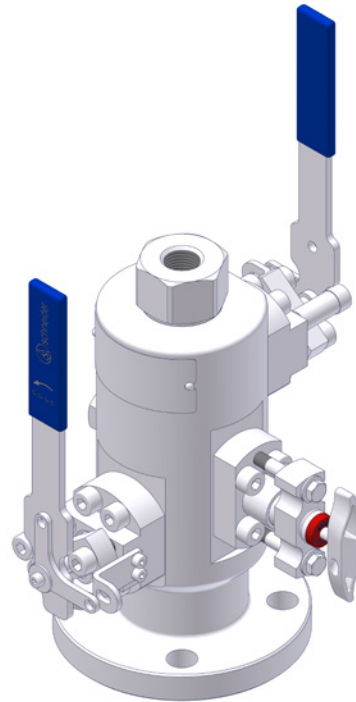

Materials of construction

Main Components	Carbon Steel	Stainless Steel	Duplex
Body	A105 resp. LF2	316/316L	F51
Body End Connector	A105 resp. LF2	316/316L	S31803
Bonnet	316/316L	316/316L	S31803
Ball	316/316L	316/316L	S31803
Stem	316/316L		S31803
Seat Carrier	316/316L		S31803
Disc Spring for Valve Seat	Inconel 718		
Primary Seal	Graphite		
Dynamic Seals (Seat and Stem) and Static Seals (Body Seals)	Graphite		

VariAS-Blocks | Ordering Information

Ordering Information

		1	2	3	4	5	6	7	8	9	10	11	12	13	14	
		D	B	2	-	N	G	C	L	N	4	-	S	C		
VariAS-Blocks																
Block & Bleed																
DD	10 mm (0.39") Bore Ball Valve (Ball / Ball)															
DE	10 mm (0.39") Bore Ball Valve (Ball / Needle)															
Double Block & Bleed																
DA	10 mm (0.39") Bore Ball Valve (Ball / Ball / Ball)															
DB	10 mm (0.39") Bore Ball Valve (Ball / Needle / Ball)															
D2	14 mm (0.55") Bore Ball Valve (Ball / Needle / Ball) ≥ Flange Size 3/4"															
DK	20 mm (0.79") Bore Ball Valve (Ball / Needle / Ball) ≥ Flange Size 1"															
Seals – Standard Valve Design								Seals – Fugitive Emission Application Design								
Packing/Body Seals				Ball Seat				Packing/Body Seals				Ball Seat				
1	PTFE			Reinforced PTFE*1				D	Graphite			Reinforced PTFE*1				
2	Graphite			Reinforced PTFE*1				E	PTFE			Reinforced PTFE*1				
3	PTFE			PEEK*1				F	PTFE			PEEK*1				
4	Graphite			PEEK*1				G	Graphite			PEEK*1				
6	Graphite + O-Ring RGD			Reinforced PTFE*1				M	Graphite			Metal Seated*3				
8	Graphite + O-Ring RGD			PEEK*1												
V	Graphite			Metal Seated												
X	Lip Seal + Graphite 10k			Metal Seated												
Y	Lip Seal + Graphite 15k			Metal Seated												
Process Connection																
ASME Flange Size																
NA	1/2" RF		NJ	1" RTJ		NR	2 1/2" RF									
NC	1/2" RTJ		NK	1 1/2" RF		NT	2 1/2" RTJ									
ND	3/4" RF		NM	1 1/2" RTJ		NU	3" RF									
NF	3/4" RTJ		NN	2" RF		NW	3" RTJ									
NG	1" RF		NQ	2" RTJ												
Process Connection (continued)																
ASME Flange Class																
A	150		D	900*4												
B	300		E	1,500												
C	600		F	2,500												
Outlet Connection																
ASME Flange Size						Thread										
NA	1/2" RF		NJ	1" RTJ		NR	2 1/2" RF		LG	Female G (EN837-1)						
NC	1/2" RTJ		NK	1 1/2" RF		NT	2 1/2" RTJ		JN	Male NPT						
ND	3/4" RF		NM	1 1/2" RTJ		NU	3" RF		LN	Female NPT						
NF	3/4" RTJ		NN	2" RF		NW	3" RTJ		LH	Female G (DIN 3852)						
NG	1" RF		NQ	2" RTJ												
Outlet Connection (continued)																
ASME Flange Class						Thread Size										
A	150		D	900*4		4	1/2"									
B	300		E	1,500		6	3/4"									
C	600		F	2,500		8	1"									
Body Material																
C	A105		L	A350 LF2		V	Alloy 625 UNS N06625									
F	Duplex UNS S31803		M	Alloy 400 UNS N04400		D	Super Duplex UNS S32750									
H	Alloy C-276 UNS N10276		S	1.4401 / 1.4404 / 316 / 316L		B	6Mo UNS S31254									
Vent Connection																
C	1/4 NPT Female		E	1/2 NPT Female												
D	1/4 NPT Female plugged		F	1/2 NPT Female plugged												
Options																
1	Sampling Probe (starting from 1 1/2" Flange Size)										K	Spring loaded floating ball seats (only available for Valve Design 6 and 8)				
Q	Needle Valve: Stainless Steel Handwheel and Locking Plate Design										T	All head units in OS&Y design				
R	Needle Valve: Stainless Steel Handwheel and Locking Plate Design incl. Padlock															
V	Injection Probe incl. Check Valve (starting from 1 1/2" Flange Size) – Available for 3/8" Bore Ball Valve only															
W	All Valves lockable incl. Padlock															
	Note: Flange x Thread Design – Position of Secondary Isolation Valve on opposite side of Primary Isolation Valve															

*1 Available for Ø 10, Ø 14 and Ø 20.

*2 Specify Option "K" for this Valve Design

*3 Available for Ø 10 only.

*4 Relevant for Flange Sizes ≥ 3" only. For Flange Sizes 1/2" to 2 1/2" Class 1,500 (Code E) to be used.

Wetted Parts according to above mentioned material list are supplied according to NACE MR0175/MR0103 and ISO 15156 and ISO 15156 / ISO 17945 (latest issue).

Note: Not every configuration which can be created in the ordering information is feasible / available.

Accessories for Monoflanges and VariAS-Blocks

Gauge Syphons

Designed to replace the pigtail syphon, this compact style provides a thermal barrier between hot vapors and the pressure instrument. This Gauge Syphon reduces also the amount of potential gauge whip on vibrating lines by bringing the gauge closer to the process connection.

Ordering Information see Catalogue 'AS-0201 | Gauge Valves and Pressure Gauge Accessories'.

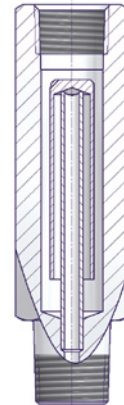

Swivel Gauge Adapters

The Swivel Gauge Adapters enable the easy positioning of the pressure instrument in any direction through 360°.

Ordering Information see Catalogue 'AS-2601 | E Series Valves and Manifolds'.

GS Type – For NPT Threads only

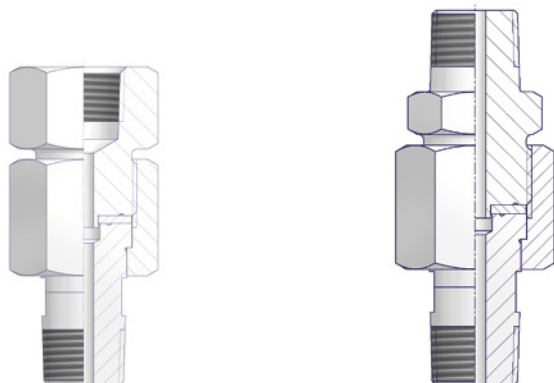

GD Type



Vent Valves, Pipe Plugs and Pipe Fittings

Ordering Information see Catalogue 'AS-2601 | E Series Valves and Manifolds'.

Vent Valve
VS Type



Vent Valve
VT Type

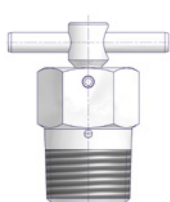

Pipe Plug
PP Type

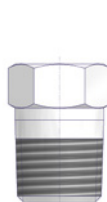

Hex Nipple
HN Type

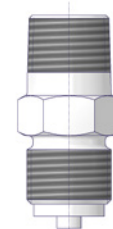

Double Block & Bleed Piping Ball Valves – Taurus Series

Taurus Series

Taurus is our Double Block & Bleed Piping Ball Valves Series. A suitable name, because it stands for process valves, to be used for example on Offshore Platforms, Metering Stations and Compressor Stations, Gas Pipelines, Refineries, etc.!

For more information see our Catalogue 'AS-4201 | Taurus Series'.

Basically we offer 2 different designs: 2 Piece Design and 3 Piece Design, Both Flanged Style and Side Entry.

Features

- Designed in accordance with Industry Standards i.e. ASME B16.34, ASME B31.3, ASME B16.5, API 6D / ISO 14313
- Full Bore or Reduced Bore
- Standard Materials of Construction are forged Carbon Steel LF2, Stainless Steel 316 and Duplex
- Pressure Class 150 to 2,500
- Fire Safe in accordance to API 607 and ISO 10497
- Compliant to NACE MR0175 and ISO 15156
- Factory Tested in accordance with ASME B16.34, API 6D / ISO 14313, ISO 5208
- Manufactured in accordance with the Pressure Equipment Directive
- Ball Seat Material: PTFE, Devlon, PEEK or Metal Seated
- Stem Seal Material: FKM, HNBR – RGD resistant (RGD = Rapid Gas Decompression) or Graphite
- Anti-Blowout Stem Design and Anti-Static Design
- Weld Inlay: Seat pocket and seal area overlay on request
- Bi-Directional: The Taurus Series Floating and Trunnion Ball Valves are bi-directional as standard.
- Painting: The valves can be supplied with any kind of adequate coatings for environmental protection, according to customers specifications.
- Certification and Traceability: Material test certificates 3.1 according to EN 10204. A unique code is stamped on all relevant components linking them with their material and chemical analysis certificates.

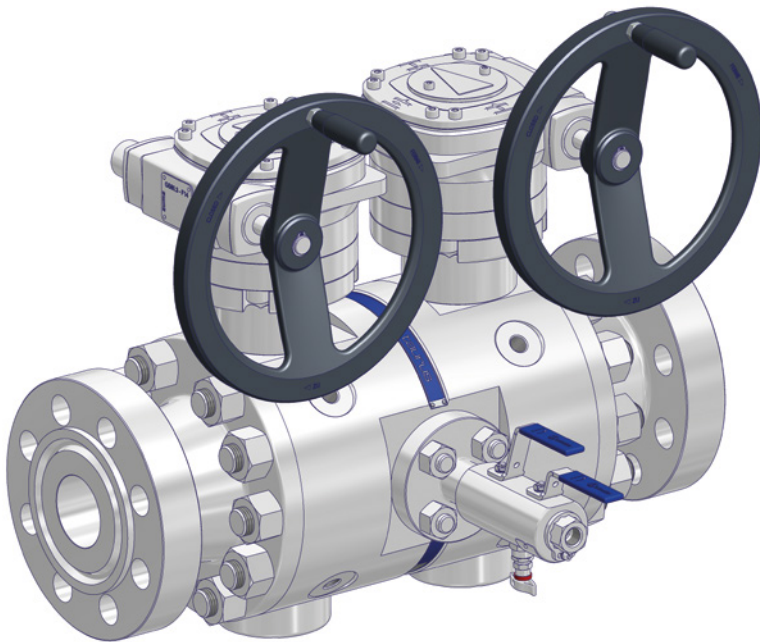

3 Piece Design, Flanged Style

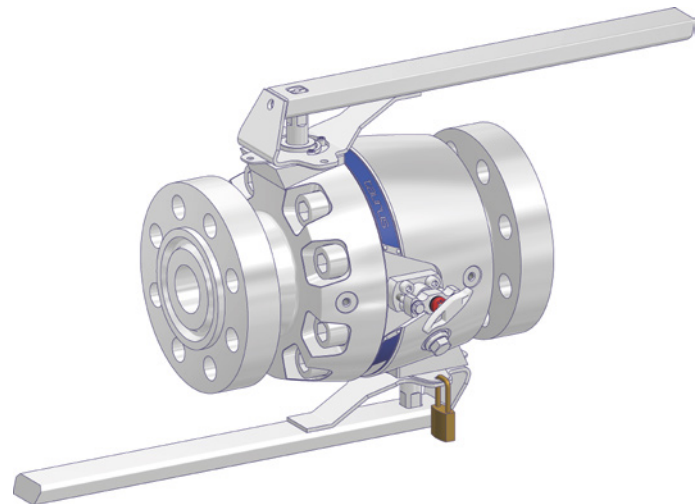

2 Piece Design, Flanged Style

YOUR BENEFITS:

- ✓ Compact Assembly
- ✓ Reduced Weight
- ✓ Reduced Leak Paths
- ✓ Reduced Installation and Maintenance Costs
- ✓ Significant Space Savings

Technical Service Portal - Digital Valve Plate

Digital Valve Plate for Valves and Manifolds

The VariAS-Blocks and Monoflanges manufactured by the AS-Schneider Group are now marked with a unique QR-code (acc. to IEC 61406). That QR-code provides easy access to static product information like material properties, certificates and physical dimensions via CAD drawings. It also includes operating and installation instructions or spare parts or replacement information.

Technical Specification



Activity - Specific Docs



Individual Drawings



Spare Part



Technical Support



How it works

If you have a Monoflange or VariAS-Block with QR code (acc. to IEC 61406) in your hand or installed in your plant, you can now access the product information very easy. The access is straightforward:



Maintenance Benefits

All technically relevant information on the product can always be retrieved directly.

Identification

Easy access to relevant product information on the go.

Error-free assembly

Automated error-free equipment identification at the incoming good inspection & during field installation.

Fast maintenance

Easier and faster maintenance and repair cycles. This is possible due to direct access to spare parts or replacement units.

Open interface

Operators can link this information into their respective asset and operation management system acc. to IEC 61406 and VDI 2770.

Environmental friendly

Environmentally responsible disassembly and disposal. Will be adapted to future EU circular economy requirements.

Check the DVP of your valves and manifolds:
www.qr4v.de

YOUR GLOBAL PARTNER

for Instrumentation and
Double Block & Bleed Valves

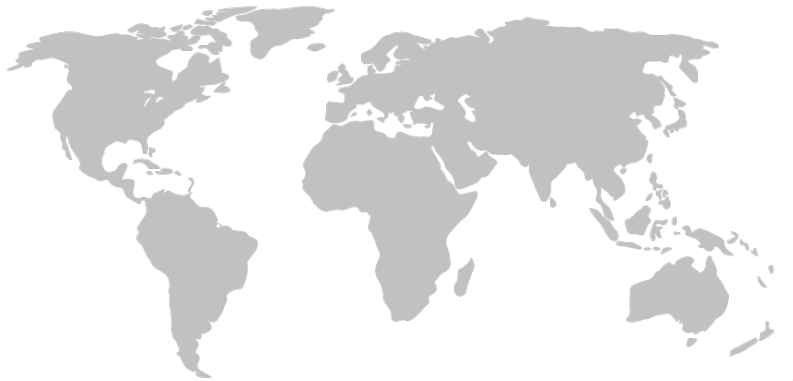

Visit us on:



ARMATURENFABRIK FRANZ SCHNEIDER GMBH + CO. KG
World Headquarters
Bahnhofplatz 12, 74226 Nordheim, Germany
Tel: +49 7133 101-0
www.as-schneider.com



ARMATURENFABRIK FRANZ SCHNEIDER SRL
Gradinari 32-38, 100404 Ploiesti
Romania
Tel: +40 244 384 963
www.as-schneider.ro



AS-SCHNEIDER ASIA-PACIFIC PTE. LTD.
970 Toa Payoh North, #02-12/14/15, Singapore 318992,
Singapore
Tel: +65 62 51 39 00
www.as-schneider.sg



AS-SCHNEIDER AMERICA, INC.
17449 Village Green Dr, Houston, TX 77040
United States of America
Tel: +1 281 760 1025
www.as-schneider.com



AS-SCHNEIDER MIDDLE EAST FZE
P.O. Box 18749, Dubai
United Arab Emirates
Tel: +971 4 880 85 75
www.as-schneider.ae



AS-SCHNEIDER INDIA PRIVATE LIMITED
Rathinam Techzone Campus, Eachanari
641021 Coimbatore, Tamil Nadu, India
Tel: +91 999 544 2201
www.as-schneider.com

